



## List of project work/field work/ internships done by students which are part of Calcutta Univeristy curriculum

### Total Student List/summary Page: 1 -37

| Serial No | Page No | Programme name                      | COURSE Code           |
|-----------|---------|-------------------------------------|-----------------------|
| 1         | 38-45   | HISTORY HONOURS (SEM III)           | HISA (SEC A (1))      |
| 2         | 46-53   | HISTORY HONOURS (SEM III)           | HISA SEC-B (2)        |
| 3         | 54-68   | GEOGRAPHY (HONS) SEM V              | GEOA (GEO-A-CC5-11-P) |
| 4         | 69-77   | SOCIOLOGY (GEN ) SEM V              | SOCG DSE A1           |
| 5         | 78-83   | BOTANY GEN SEM 1                    | BOTG -CC1/GE1         |
| 6         | 84-90   | BOTANY GEN SEM V                    | BOTG-DSE-A-5-1-P      |
| 7         | 91-100  | PHYSICS GEN SEM IV                  | PHSG SEC B1           |
| 8         | 101-111 | BENGALI HONS SEM VI                 | BNGA-DSEB-6-4         |
| 9         | 112-118 | BOTANY GEN SEM 2                    | BOTG -CC2/GE2         |
| 10        | 119-125 | BOTANY GEN SEM VI                   | BOTG -DSE B1          |
| 11        | 126-144 | ENVIRONMENTAL STUDIESGENERAL SEM II | AECC 2                |
| 12        | 145-160 | ENVIRONMENTAL STUDIESHONOURS SEM II | AECC 2                |
| 13        | 161-171 | COMPUTER SCIENCE SEM VI             | CC13 and CC14         |
| 14        | 172-175 | GEOGRAPHY SEM VI                    | GEO-A-CC-6-13-P       |
| 15        | 176-179 | GEOGRAPHY SEM VI                    | GEO-A-CC-6-14-P       |
| 16        | 180-187 | SANSKRIT SEM VI                     | SANA CC14             |

## List of students along with the details of title, place of work, duration etc.

### 1.3.2 Percentage of students undertaking project work/field work/internship (Data for the latest completed academic year)

| Programme name            | Program Code     | List of students undertaking project work/field work/internship | Duration | Place of Work                        | Link to the relevant document   |
|---------------------------|------------------|---|----------|--------------------------------------|---|
| HISTORY HONOURS (SEM III) | HISA (SEC A (1)) | Chandeshree Chatterjee  | 20 hours | Danish Govt House, Serampore Hooghli | <a href="https://seramporegirlscollege.org/main/site/Naac/view/5">https://seramporegirlscollege.org/main/site/Naac/view/5</a> |
|                           |                  | Riya Dhara  |          |                                      |   |
|                           |                  | Sangita Man   |          |                                      |   |
|                           |                  | Sathi Sarkar  |          |                                      |   |
|                           |                  | Sunidhi Kumari Das  |          |                                      |   |
|                           |                  | Dipa Kumari Rajak   |          |                                      |   |
|                           |                  | Manisha Paswan  |          |                                      |   |
|                           |                  | Megha Paswan  |          |                                      |   |
|                           |                  | Sabnam Rizwana  |          |                                      |   |
|                           |                  | Sumitra Km. Shaw  |          |                                      |   |
|                           |                  | Ritika Choudhury  |          |                                      |   |
|                           |                  | Jyoti Kumari  |          |                                      |   |

|  |                     |  |  |
|--|---------------------|--|--|
|  | Karishma Paswan     |  |  |
|  | Neha Shaw           |  |  |
|  | Antrika Chakravarty |  |  |
|  | Ipsita Majumdar     |  |  |
|  | Tiyasha Bag         |  |  |
|  | Priti Pal           |  |  |
|  | Priti Saini         |  |  |
|  | Swagata Ghosh       |  |  |
|  | Pallabi Ghosh       |  |  |
|  | Shilpa Mallik       |  |  |
|  | Barsha Das          |  |  |
|  | Lisa Bar            |  |  |
|  | Bidisa Ghosh        |  |  |
|  | Amrita Mukherjee    |  |  |
|  | Ritika Paul         |  |  |
|  | Awdita Ghosh        |  |  |
|  | Sanghamita Bhunia   |  |  |
|  | Mamon Roy           |  |  |
|  | Mandira Roy         |  |  |
|  | Pamela Roy          |  |  |
|  | Arati Shaw          |  |  |
|  | Bilquis Saba        |  |  |
|  | Riya Chowdhury      |  |  |
|  | Sania Israr         |  |  |
|  |                     |  |  |
|  | Debalina Sarkar     |  |  |
|  | Bidisha Sarkar      |  |  |
|  | Parui Parui         |  |  |
|  | Sumita Das          |  |  |

|  |                            |  |  |
|--|----------------------------|--|--|
|  | Sarnali Das                |  |  |
|  | Mandira Malik              |  |  |
|  | Rimi Das                   |  |  |
|  | Saraswati Sardar           |  |  |
|  | Shilpa Manna               |  |  |
|  | Debasmita<br>Bhattacharaya |  |  |
|  | Susmita Mukherjee          |  |  |
|  | Diya Dey                   |  |  |
|  | Sharabanti Patra           |  |  |
|  | Laboni Patra               |  |  |
|  | Sayani Mandal              |  |  |
|  | Sumita Nayek               |  |  |
|  | Soubarni Sikdar            |  |  |
|  | Rupa Das                   |  |  |
|  | Jayeeta Sardar             |  |  |
|  | Sneha Santra               |  |  |
|  | Sukanya Das                |  |  |
|  |                            |  |  |
|  | Sunetra Bhukta             |  |  |
|  | Puja Dar                   |  |  |
|  | Rishita Bera               |  |  |
|  | Sathi Pal                  |  |  |
|  | Trishna Patowri            |  |  |
|  | Soumi Das                  |  |  |
|  | Anisha Khatun              |  |  |
|  | Julekha Khatun             |  |  |
|  | Sanchayita Chakravarty     |  |  |
|  | Ashmita Kumari Thakur      |  |  |
|  | Shabana Paswan             |  |  |

|                              |                |                            |         |   |   |
|------------------------------|----------------|----------------------------|---------|---|---|
|                              |                | nNeha Rajbhar              |         |   |   |
|                              |                | Neha Choudhury             |         |   |   |
|                              |                | Sneha Das                  |         |   |   |
|                              |                | Koyal Maitra               |         |   |   |
|                              |                | Wahida Saheli              |         |   |   |
|                              |                | Shaheen Parveen            |         |   |   |
|                              |                | Nisharani Halder           |         |   |   |
|                              |                | Sima Kumari Shaw           |         |   |   |
|                              |                | Neha Kumari Das            |         |   |   |
|                              |                | Shimran Kumari Shaw        |         |   |   |
|                              |                | Sudeshna Pal               |         |   |   |
|                              |                | Payel Bag                  |         |   |   |
|                              |                | Arpita Khan                |         |   |   |
|                              |                |                            |         |   |   |
| HISTORY HONOURS<br>(SEM III) | HISA SEC-B (2) | Chandrashree<br>Chatterjee | 6 hours | Serampore Rajbari,<br>Serampore Hooghly | <a href="https://seramporegirlscollege.org/main&lt;br/&gt;site/Naac/view/5">https://seramporegirlscollege.org/main<br/>site/Naac/view/5</a> |
|                              |                | Pallabi Ghosh              |         |   |   |
|                              |                | Swagata Ghosh              |         |   |   |
|                              |                | Priti Pal                  |         |   |   |
|                              |                | Monisa Singha              |         |   |   |
|                              |                | Sania IsrarBilquis Saba    |         |   |   |
|                              |                | Riya Chowdhury             |         |   |   |
|                              |                | Shaleam Rizwana            |         |   |   |
|                              |                | Dipa Kumari Rajak          |         |   |   |
|                              |                | Jypti Kumari               |         |   |   |
|                              |                | Sunidhi Kumari Das         |         |   |   |
|                              |                | Krishna Paswan             |         |   |   |
|                              |                | Adwita Ghosh               |         |   |   |
|                              |                | Roshni Mondal              |         |   |   |
|                              |                | Nisha Dey                  |         |   |   |

|  |  |                            |  |  |  |
|--|--|----------------------------|--|--|--|
|  |  | Lisa Bar                   |  |  |  |
|  |  | Amrita Mukherjee           |  |  |  |
|  |  | Amntrika Chakarborty       |  |  |  |
|  |  | Ipshita Majumdar           |  |  |  |
|  |  | Neha Shaw                  |  |  |  |
|  |  | Lisa Bar                   |  |  |  |
|  |  | Barsha Das                 |  |  |  |
|  |  | Shipla Malik               |  |  |  |
|  |  | Ritika Paul                |  |  |  |
|  |  | Sanghamita Bhuina          |  |  |  |
|  |  | Mondira Roy                |  |  |  |
|  |  | Mamon Roy                  |  |  |  |
|  |  | Bidisha Ghosh              |  |  |  |
|  |  | Riya Dhara                 |  |  |  |
|  |  | Sangita Man                |  |  |  |
|  |  |                            |  |  |  |
|  |  | Saraswati Sardar           |  |  |  |
|  |  | Sayani Mondal              |  |  |  |
|  |  | Sukanya Das                |  |  |  |
|  |  | Subhamita Ghosh            |  |  |  |
|  |  | Nikhat Nishat              |  |  |  |
|  |  | Kum Kum Choudhury          |  |  |  |
|  |  | Sushmita Mukherjee         |  |  |  |
|  |  | Debosmita<br>Bhattacharaya |  |  |  |
|  |  | Priya Hazra                |  |  |  |
|  |  | Ngma Parveen               |  |  |  |
|  |  | Jayeta Sardar              |  |  |  |
|  |  |                            |  |  |  |
|  |  |                            |  |  |  |

|                           |                           |                       |        |                                      |   |
|---------------------------|---------------------------|-----------------------|--------|--------------------------------------|---|
|                           |                           | Neha Kumari Das       |        |                                      |   |
|                           |                           | Shaheen Parveen       |        |                                      |   |
|                           |                           | Simran Kumari Shaw    |        |                                      |   |
|                           |                           | Sima Kumari Shaw      |        |                                      |   |
|                           |                           | Anushree Roy          |        |                                      |   |
|                           |                           | Arpita Khan           |        |                                      |   |
|                           |                           | Shabana Parween       |        |                                      |   |
|                           |                           | Anisha Khatun         |        |                                      |   |
|                           |                           | Ashmita Kumari Thakur |        |                                      |   |
|                           |                           | Niru Kumari           |        |                                      |   |
|                           |                           | Neha Rajbhar          |        |                                      |   |
|                           |                           | Arpita Goldar         |        |                                      |   |
|                           |                           | Sudeshna Pal          |        |                                      |   |
|                           |                           | Payel Bag             |        |                                      |   |
|                           |                           | Priya Sharma          |        |                                      |   |
|                           |                           | Puja Das              |        |                                      |   |
|                           |                           | Sunetra Bhukta        |        |                                      |   |
| GEOGRAPHY (HONS)<br>SEM V | GEOA (GEO-A-<br>CC5-11-P) | Payel Pal             | 6 days | Mirik and Darjeeling, West<br>Bengal | <a href="https://seramporegirlscollege.org/main&lt;br/&gt;site/Naac/view/5">https://seramporegirlscollege.org/main<br/>site/Naac/view/5</a> |
|                           |                           | Sangita Koley         |        |                                      |   |
|                           |                           | Soumini Dutta         |        |                                      |   |
|                           |                           | Snehashree De         |        |                                      |   |
|                           |                           | Doniya Pramanick      |        |                                      |   |
|                           |                           | Soumi Dey             |        |                                      |   |
|                           |                           | Piyali Chandra        |        |                                      |   |
|                           |                           | Rinku Dey             |        |                                      |   |
|                           |                           | Nibedita Das          |        |                                      |   |
|                           |                           | Ankita Chandra        |        |                                      |   |
|                           |                           | Dishita De            |        |                                      |   |
|                           |                           | Suparna Adhikary      |        |                                      |   |

|                                   |             |                 |           |   |   |
|-----------------------------------|-------------|-----------------|-----------|---|---|
|                                   |             | Priti Tatawa    |           |   |   |
|                                   |             | Rupsha Dey      |           |   |   |
|                                   |             | Sanjukta Sharma |           |   |   |
|                                   |             | Arpita Malik    |           |   |   |
|                                   |             | Sujata Kayal    |           |   |   |
|                                   |             | Pallabi Majhi   |           |   |   |
|                                   |             | Barsha Malik    |           |   |   |
|                                   |             | Sanchaita Das   |           |   |   |
|                                   |             | Lisa Majumder   |           |   |   |
|                                   |             | Soma Mondal     |           |   |   |
|                                   |             | Priyanka Dalui  |           |   |   |
|                                   |             | Sneha Tudu      |           |   |   |
|                                   |             | Aiswariya Roy   |           |   |   |
|                                   |             | Shreya Ghosh    |           |   |   |
|                                   |             | Sreya Ash       |           |   |   |
|                                   |             | Barsha Nayak    |           |   |   |
|                                   |             | Saba Parween    |           |   |   |
|                                   |             | Shahin Banu     |           |   |   |
|                                   |             | Manisha Santra  |           |   |   |
| <u>SOCIOLOGY (GEN<br/>) SEM V</u> | SOCG DSE A1 | ANANYA KARMAKAR | :3 months | Serampore Area, Singur<br>Area, Barracpore Area,<br>WEST BENGAL | <a href="https://seramporegirlscollege.org/main/site/Naac/view/5">https://seramporegirlscollege.org/main<br/>site/Naac/view/5</a> |
|                                   |             | ANISHA PAL      |           |   |   |
|                                   |             | ANKITA SANTRA   |           |   |   |
|                                   |             | ANTARA GHOSH    |           |   |   |
|                                   |             | ANTARA RAY      |           |   |   |
|                                   |             | ARCHA CHAL      |           |   |   |
|                                   |             | ASIMA KHELO     |           |   |   |
|                                   |             | ASLEMA KHATUN   |           |   |   |
|                                   |             | KHADIJA KHATUN  |           |   |   |

|                  |               |                         |         |                    |   |
|------------------|---------------|-------------------------|---------|--------------------|---|
|                  |               | MADHUMITA SHAW          |         |                    |   |
|                  |               | MADHUPARNA SINGH        |         |                    |   |
|                  |               | MOUMITA BAIDYA          |         |                    |   |
|                  |               | MOUMITA DAS             |         |                    |   |
|                  |               | MOUSUMI GHOSH           |         |                    |   |
|                  |               | NAMIRA KHATUN           |         |                    |   |
|                  |               | NEHA SHA                |         |                    |   |
|                  |               | PAYEL BHAR              |         |                    |   |
|                  |               | PHALGUNI<br>CHAKRABORTY |         |                    |   |
|                  |               | PIU DEY                 |         |                    |   |
|                  |               | PRITI GANGULY           |         |                    |   |
|                  |               | PRITI ROY               |         |                    |   |
|                  |               | PRITI SANTRA            |         |                    |   |
|                  |               | PRITIKA BARMAN          |         |                    |   |
|                  |               | PRIYANKA DAS            |         |                    |   |
|                  |               | PUNAM SHAW              |         |                    |   |
|                  |               | RIYA DUTTA              |         |                    |   |
|                  |               | SABINA YIASMIN          |         |                    |   |
|                  |               | SAIMA TAZEIN            |         |                    |   |
|                  |               | SAMINA KHATUN           |         |                    |   |
|                  |               | SAMPREETY BARIK         |         |                    |   |
|                  |               | SHARMILA SARKAR         |         |                    |   |
|                  |               | SHILA PATRA             |         |                    |   |
|                  |               | SHREYA DAS              |         |                    |   |
|                  |               | SOHANI SHAW             |         |                    |   |
|                  |               | SONALI SHAW             |         |                    |   |
|                  |               | SWATI MAL               |         |                    |   |
| BOTANY GEN SEM 1 | BOTG -CC1/GE1 | Koyal Barik             | 1 month | Serampore locality | <a href="https://seramporegirlscollege.org/main/site/Naac/view/5">https://seramporegirlscollege.org/main/site/Naac/view/5</a> |
|                  |               | Puja Ghosh              |         |                    |   |
|                  |               | Shruti Kumari           |         |                    |   |

|                     |                      |                    |                        |  |   |
|---------------------|----------------------|--------------------|------------------------|--|---|
|                     |                      | Neha Singh         |                        |  |   |
|                     |                      | Supriya Deyase     |                        |  |   |
| BOTANY GEN SEM V    | BOTG-DSE-A-5-1-P     | Anannya Das        | 1 month                | Serampore locality                       | <a href="https://seramporegirlscollege.org/main/site/Naac/view/5">https://seramporegirlscollege.org/main/site/Naac/view/5</a> |
|                     |                      | June Ghosh         |                        |  |   |
|                     |                      | Mahima Chalki      |                        |  |   |
|                     |                      | Shrestha Guha      |                        |  |   |
|                     |                      | Priti Maji         |                        |  |   |
|                     |                      | Jayashree Debnath  |                        |  |   |
| PHYSICS GEN SEM IV  | PHSG SEC B1          | Nishu Bhagat       | 6 months ( 1 semester) | Physics Lab, Serampore Girls College     | <a href="https://seramporegirlscollege.org/main/site/Naac/view/5">https://seramporegirlscollege.org/main/site/Naac/view/5</a> |
|                     |                      | Shana Shahid       |                        |  |   |
|                     |                      | Asiya Parvin       |                        |  |   |
|                     |                      | Mosaheeda Tabassum |                        |  |   |
| BENGALI HONS SEM VI | <b>BNGA-DSEB-6-4</b> | Riya Santra        | 8 hours                | Shantiniketan, Bolpur Srijani Silpa Gram | <a href="https://seramporegirlscollege.org/main/site/Naac/view/5">https://seramporegirlscollege.org/main/site/Naac/view/5</a> |
|                     |                      | Dipannita Das      |                        |  |   |
|                     |                      | Nikita Purkait     |                        |  |   |
|                     |                      | Soumi Adak         |                        |  |   |
|                     |                      | Sukriti Kundu      |                        |  |   |
|                     |                      | Hritika Malakar    |                        |  |   |
|                     |                      | Arpita Mandal      |                        |  |   |
|                     |                      | Trisha Das         |                        |  |   |
|                     |                      | Arpita Mandal      |                        |  |   |
|                     |                      | Tiyasha Dholey     |                        |  |   |
|                     |                      | Papiya Santra      |                        |  |   |
|                     |                      | Rama Das           |                        |  |   |
|                     |                      | Dona Koley         |                        |  |   |
|                     |                      | Rachana Majumdar   |                        |  |   |
|                     |                      | Shraddha Dutta     |                        |  |   |
|                     |                      | Ishita Nandy       |                        |  |   |

|                         |                        |                   |   |  |   |
|-------------------------|------------------------|-------------------|---|--|---|
|                         |                        | Mampi Santra      |   |  |   |
|                         |                        | Fatema Khatun     |   |  |   |
| BOTANY GEN SEM 2        | BOTG -CC2/GE2          | Koyal Barik       | 1 month                                       | Chinsurah, Hooghly                           | <a href="https://seramporegirlscollege.org/main/site/Naac/view/5">https://seramporegirlscollege.org/main/site/Naac/view/5</a> |
|                         |                        | Puja Ghosh        |   |  |   |
|                         |                        | Shruti Kumari     |   |  |   |
|                         |                        | Neha Singh        |   |  |   |
| BOTANY GEN SEM VI       | BOTG -DSE B1           | Anannya Das       | 8 hours                                       | Rice research station,<br>Chinsurah, Hooghly | <a href="https://seramporegirlscollege.org/main/site/Naac/view/5">https://seramporegirlscollege.org/main/site/Naac/view/5</a> |
|                         |                        | June Ghosh        |   |  |   |
|                         |                        | Mahima Chalki     |   |  |   |
|                         |                        | Priti Maji        |   |  |   |
|                         |                        | Jayashri Debnath  |   |  |   |
| COMPUTER SCIENCE SEM VI | CMSA CC13 & CC14       | Sohinee Sengupta  | Computer Science Lab, Serampore Girls College | 6 months ( 1 semester)                       | <a href="https://seramporegirlscollege.org/main/site/Naac/view/5">https://seramporegirlscollege.org/main/site/Naac/view/5</a> |
|                         |                        | Soma Das          |   |  |   |
|                         |                        | Prakriti Banerjee |   |  |   |
|                         |                        | Punam Kumari      |   |  |   |
|                         |                        | Ekta Prasad       |   |  |   |
|                         |                        | Swati Paswan      |   |  |   |
|                         |                        | Sathi Som         |   |  |   |
|                         |                        | Elisa Mitra       |   |  |   |
| GEOGRAPHY SEM VI        | <b>GEO-A-CC-6-13-P</b> | Payel Pal         | Geography Lab, Serampore Girls College        | 6 months ( 1 semester)                       | <a href="https://seramporegirlscollege.org/main/site/Naac/view/5">https://seramporegirlscollege.org/main/site/Naac/view/5</a> |
|                         |                        | Sangita Koley     |   |  |   |
|                         |                        | Soumini Dutta     |   |  |   |
|                         |                        | Snehashree De     |   |  |   |
|                         |                        | Doniya Pramanick  |   |  |   |
|                         |                        | Soumi Dey         |   |  |   |

|                  |                 |                  |  |                        |   |
|------------------|-----------------|------------------|--|------------------------|---|
|                  |                 | Piyali Chandra   |  |                        |   |
|                  |                 | Rinku Dey        |  |                        |   |
|                  |                 | Nibedita Das     |  |                        |   |
|                  |                 | Ankita Chandra   |  |                        |   |
|                  |                 | Dishita De       |  |                        |   |
|                  |                 | Suparna Adhikary |  |                        |   |
|                  |                 | Priti Tatawa     |  |                        |   |
|                  |                 | Rupsha Dey       |  |                        |   |
|                  |                 | Sanjukta Sharma  |  |                        |   |
|                  |                 | Arpita Malik     |  |                        |   |
|                  |                 | Sujata Kayal     |  |                        |   |
|                  |                 | Pallabi Majhi    |  |                        |   |
|                  |                 | Barsha Malik     |  |                        |   |
|                  |                 | Sanchaita Das    |  |                        |   |
|                  |                 | Lisa Majumder    |  |                        |   |
|                  |                 | Soma Mondal      |  |                        |   |
|                  |                 | Priyanka Dalui   |  |                        |   |
|                  |                 | Sneha Tudu       |  |                        |   |
|                  |                 | Aiswariya Roy    |  |                        |   |
|                  |                 | Shreya Ghosh     |  |                        |   |
|                  |                 | Sreya Ash        |  |                        |   |
|                  |                 | Barsha Nayak     |  |                        |   |
|                  |                 | Saba Parween     |  |                        |   |
|                  |                 | Shahin Banu      |  |                        |   |
|                  |                 | Manisha Santra   |  |                        |   |
| GEOGRAPHY SEM VI | GEO-A-CC-6-14-P | Payel Pal        | Geography Lab,<br>Serampore Girls<br>College | 6 months ( 1 semester) | <a href="https://seramporegirlscollege.org/main/site/Naac/view/5">https://seramporegirlscollege.org/main/site/Naac/view/5</a> |
|                  |                 | Sangita Koley    |  |                        |   |
|                  |                 | Soumini Dutta    |  |                        |   |

|  |                  |  |  |
|--|------------------|--|--|
|  | Snehashree De    |  |  |
|  | Doniya Pramanick |  |  |
|  | Soumi Dey        |  |  |
|  | Piyali Chandra   |  |  |
|  | Rinku Dey        |  |  |
|  | Nibedita Das     |  |  |
|  | Ankita Chandra   |  |  |
|  | Dishita De       |  |  |
|  | Suparna Adhikary |  |  |
|  | Priti Tatawa     |  |  |
|  | Rupsha Dey       |  |  |
|  | Sanjukta Sharma  |  |  |
|  | Arpita Malik     |  |  |
|  | Sujata Kayal     |  |  |
|  | Pallabi Majhi    |  |  |
|  | Barsha Malik     |  |  |
|  | Sanchaita Das    |  |  |
|  | Lisa Majumder    |  |  |
|  | Soma Mondal      |  |  |
|  | Priyanka Dalui   |  |  |
|  | Sneha Tudu       |  |  |
|  | Aiswariya Roy    |  |  |
|  | Shreya Ghosh     |  |  |
|  | Sreya Ash        |  |  |
|  | Barsha Nayak     |  |  |
|  | Saba Parween     |  |  |
|  | Shahin Banu      |  |  |
|  | Manisha Santra   |  |  |

|                       |                  |                         |  |                        |   |
|-----------------------|------------------|-------------------------|--|------------------------|---|
| ENVIRONMENTAL STUDIES | AECC 2 (General) | RIYA DEY                | Serampore Girls' College,<br>WEST BENGAL | 6 months ( 1 semester) | <a href="https://seramporegirlscollege.org/main/site/Naac/view/5">https://seramporegirlscollege.org/main/site/Naac/view/5</a> |
|                       |                  | BARNALI DAS             |  |                        |   |
|                       |                  | RIYA BISWAS             |  |                        |   |
|                       |                  | BHUMIKA BISWAL          |  |                        |   |
|                       |                  | PRITHA GHOSH            |  |                        |   |
|                       |                  | ANCHAL SINGH            |  |                        |   |
|                       |                  | RIYANKA DAS             |  |                        |   |
|                       |                  | SNEHA DAS<br>BAIRAGHYA  |  |                        |   |
|                       |                  | ANAMIKA ROY             |  |                        |   |
|                       |                  | SHARMISTA SANTRA        |  |                        |   |
|                       |                  | SANDHITA<br>CHAKRABORTY |  |                        |   |
|                       |                  | SUMITRA RAJBHAR         |  |                        |   |
|                       |                  | SABANA YEASMIN          |  |                        |   |
|                       |                  | SUMAN KUMARI<br>SINGH   |  |                        |   |
|                       |                  | RITU MISHRA             |  |                        |   |
|                       |                  | TANUSHREE PAUL          |  |                        |   |
|                       |                  | RIJUTA SAHA             |  |                        |   |
|                       |                  | KANKANA PAL             |  |                        |   |
|                       |                  | NEHA KHATUN             |  |                        |   |
|                       |                  | SAHIN PARVIN            |  |                        |   |
|                       |                  | AYESA KHATUN            |  |                        |   |
|                       |                  | AIRIN KHATUN            |  |                        |   |
|                       |                  | IPSITA DEY              |  |                        |   |
|                       |                  | RANITA GARANG           |  |                        |   |
|                       |                  | SHIVANI PANDEY          |  |                        |   |
|                       |                  | KOYEL HAZRA             |  |                        |   |

|  |                         |  |  |
|--|-------------------------|--|--|
|  | SUMANA BAG              |  |  |
|  | PRAGATI DUTTA           |  |  |
|  | SUKRIYA KHATUN          |  |  |
|  | SAHENA YEASMIN          |  |  |
|  | KEYA KOLEY              |  |  |
|  | ARNABI CHALKI           |  |  |
|  | PARAMITA GOLDER         |  |  |
|  | MOUMITA MALIK           |  |  |
|  | MUSKAN SHAW             |  |  |
|  | RIYA GOLDAR             |  |  |
|  | SAHINA PARVIN           |  |  |
|  | POULAMI GHOSH           |  |  |
|  | MOSAMMAT SAIRIN<br>NESA |  |  |
|  | SHREYA GHOSH            |  |  |
|  | SHILPA DEY              |  |  |
|  | PRIYA SHAW              |  |  |
|  | LIJA KOLEY              |  |  |
|  | RIYA MANNA              |  |  |
|  | MAUBANI PAUL            |  |  |
|  | MILI BAG                |  |  |
|  | MADHUMITA MONDAL        |  |  |
|  | SAYANTIKA KAR           |  |  |
|  | TITHI DAS               |  |  |
|  | AFROZA KHATUN           |  |  |
|  | SANDIPA KUMARI RAM      |  |  |
|  | ARATI KUMARI SHAW       |  |  |
|  | NIVEDITA DAS            |  |  |
|  | ANKITA SINGHA           |  |  |
|  | MINATI KARMAKAR         |  |  |

|  |                  |  |  |  |
|--|------------------|--|--|--|
|  | JAYA JAISWARA    |  |  |  |
|  | DIPIKA GHOSH     |  |  |  |
|  | SALMA KHATUN     |  |  |  |
|  | TUHINA KHATUN    |  |  |  |
|  | RIMPA POREL      |  |  |  |
|  | HABIBA KHATUN    |  |  |  |
|  | RIKTA PAL        |  |  |  |
|  | DIYA PAL         |  |  |  |
|  | MOUPRIYA DAS     |  |  |  |
|  | PRITI BAHADUR    |  |  |  |
|  | RINI KARMAKAR    |  |  |  |
|  | ASMITA PATRA     |  |  |  |
|  | PINKI SAMANTA    |  |  |  |
|  | SHREYASHRI KUNDU |  |  |  |
|  | ANANYA BHANDARY  |  |  |  |
|  | MAMALI PRADHAN   |  |  |  |
|  | RAJANI GUPTA     |  |  |  |
|  | PRIYA MANNA      |  |  |  |
|  | TANUSREE DAS     |  |  |  |
|  | BATTULA KALPANA  |  |  |  |
|  | PRITI SHARMA     |  |  |  |
|  | PUJA RAUTH       |  |  |  |
|  | ANOWARA KHATUN   |  |  |  |
|  | SUKANYA BERA     |  |  |  |
|  | MONALISHA PAUL   |  |  |  |
|  | TAMANA PARWEEN   |  |  |  |
|  | RUKSAR KHATUN    |  |  |  |
|  | RUPSA DAS        |  |  |  |
|  | SWETA KUMARI     |  |  |  |
|  | SANTANA BARIK    |  |  |  |

|  |                  |  |  |  |
|--|------------------|--|--|--|
|  | SHREYA PATRA     |  |  |  |
|  | SNEHA MAITY      |  |  |  |
|  | SNEHA DAS        |  |  |  |
|  | PREETI OJHA      |  |  |  |
|  | SWETA GUPTA      |  |  |  |
|  | RUNI PANDEY      |  |  |  |
|  | RINI MAITY       |  |  |  |
|  | RITIKA SINGHA    |  |  |  |
|  | DEVI CHAKRABORTY |  |  |  |
|  | FARAHANA KHATUN  |  |  |  |
|  | MITHU SARKAR     |  |  |  |
|  | SANGITA PATRA    |  |  |  |
|  | PAYEL POREL      |  |  |  |
|  | TINA DHARA       |  |  |  |
|  | SANTOSHI HARI    |  |  |  |
|  | DIPA DAS         |  |  |  |
|  | SHREYA KAR       |  |  |  |
|  | ANANYA PONDA     |  |  |  |
|  | KAJAL SHAW       |  |  |  |
|  | PRIYASHA GHOSH   |  |  |  |
|  | SUSHAMA TANTI    |  |  |  |
|  | BARSHA KOLEY     |  |  |  |
|  | MOUMITA SANTRA   |  |  |  |
|  | MOUMITA DAS      |  |  |  |
|  | SALONI SHAW      |  |  |  |
|  | SNEHA MITRA      |  |  |  |
|  | BARSHA DHARA     |  |  |  |
|  | NEHA ADAK        |  |  |  |
|  | FARJANA YEASMIN  |  |  |  |
|  | SABIYA KHATUN    |  |  |  |

|  |                  |  |  |
|--|------------------|--|--|
|  | ANKITA PAL       |  |  |
|  | LABONI DEY       |  |  |
|  | URMI KARMAKAR    |  |  |
|  | SABNAM YEASMIN   |  |  |
|  | TUHINA YADAV     |  |  |
|  | ANJALI PRADHAN   |  |  |
|  | KAKALI BERA      |  |  |
|  | NOOR SABA        |  |  |
|  | ARPITA PANJA     |  |  |
|  | NIDHI GHOSH      |  |  |
|  | KHOOSHBU TIWARI  |  |  |
|  | RIMPA DAS        |  |  |
|  | NEHA DAS         |  |  |
|  | AFSANA KHATOON   |  |  |
|  | MOUPARNA SANTRA  |  |  |
|  | ARPITA KOLE      |  |  |
|  | KANKANA BARICK   |  |  |
|  | KEYA MRIDHA      |  |  |
|  | NANDINI GHOSH    |  |  |
|  | ANKANA BOSE      |  |  |
|  | KEYA CHAKRABORTY |  |  |
|  | RIYA ADHIKARY    |  |  |
|  | PUJA YADAB       |  |  |
|  | SUDIPA DAS       |  |  |
|  | SUSMITA ROY      |  |  |
|  | PRIYA MANNA      |  |  |
|  | SNIGDHA SANTRA   |  |  |
|  | PRITHA DAS       |  |  |
|  | TITLI DE         |  |  |
|  | ARATI SHARMA     |  |  |

|  |                         |  |  |  |
|--|-------------------------|--|--|--|
|  | BITHIKA SANTRA          |  |  |  |
|  | SUPRIYA ADAK            |  |  |  |
|  | RAI DUTTA               |  |  |  |
|  | SABNAM KHATOON          |  |  |  |
|  | SARIA KHATUN            |  |  |  |
|  | MOUSUMI DAS             |  |  |  |
|  | NIKITA DAS              |  |  |  |
|  | SOUMI PATRA             |  |  |  |
|  | SMRITI PATRA            |  |  |  |
|  | RATI MAJHI              |  |  |  |
|  | SNEHA DEBNATH           |  |  |  |
|  | SOUMITA DAS             |  |  |  |
|  | SHRUTI THAKUR           |  |  |  |
|  | ASHIA PARVIN            |  |  |  |
|  | MOUMITA KAR             |  |  |  |
|  | PUNAM SINGH             |  |  |  |
|  | SAHELI SARKAR           |  |  |  |
|  | ANUSHRI SARKAR          |  |  |  |
|  | SWETA KUMARI<br>TIIWARI |  |  |  |
|  | RUPA PRASAD             |  |  |  |
|  | ANKITA ROY              |  |  |  |
|  | ASMINA KHATUN           |  |  |  |
|  | ANUKTA PYNE             |  |  |  |
|  | PRITHA SANTRA           |  |  |  |
|  | SWARNALI DAS            |  |  |  |
|  | RIMPA MAITY             |  |  |  |
|  | RUPSHA PAL              |  |  |  |
|  | SALAHA KHATOON          |  |  |  |
|  | RUKSAD KHATUN           |  |  |  |

|  |                     |  |  |  |
|--|---------------------|--|--|--|
|  | PUNAM KUMARI PRASAD |  |  |  |
|  | RUKSHA KHATUN       |  |  |  |
|  | SAMPA DAS           |  |  |  |
|  | KOYEL POREL         |  |  |  |
|  | ISHNEHA SHAW        |  |  |  |
|  | SHIPRA KHANRA       |  |  |  |
|  | NAFISA PARVEEN      |  |  |  |
|  | SOMASHREE DAS       |  |  |  |
|  | SUNAMI DEY          |  |  |  |
|  | ISHITA KUMARI       |  |  |  |
|  | TIASA SANTRA        |  |  |  |
|  | SAMAPTI BAUL        |  |  |  |
|  | KHURSIDA KHATUN     |  |  |  |
|  | AMINA KHATUN        |  |  |  |
|  | TANIMA KOLEY        |  |  |  |
|  | ARPITA BISWAS       |  |  |  |
|  | SUSHMA TIWARI       |  |  |  |
|  | PIYASA NANDI        |  |  |  |
|  | BINITA SAHA         |  |  |  |
|  | UJALA KUMARI YADAV  |  |  |  |
|  | AYANTIKA SAHA       |  |  |  |
|  | BARSHA DAS          |  |  |  |
|  | PRIYANKA BARMAN     |  |  |  |
|  | PAYEL CHAKRABORTY   |  |  |  |
|  | NOSIN NASIM         |  |  |  |
|  | RUCHI SINGH         |  |  |  |
|  | MAMATA PARIDA       |  |  |  |
|  | KEYA BHOWMICK       |  |  |  |
|  | SNEHA DAS           |  |  |  |

|  |  |                 |  |  |  |
|--|--|-----------------|--|--|--|
|  |  | RUKSAR KHATUN   |  |  |  |
|  |  | SHABNAM         |  |  |  |
|  |  | BHATTACHARYA    |  |  |  |
|  |  | DELESHWARY SHAW |  |  |  |
|  |  | PRIYA SANTRA    |  |  |  |
|  |  | ASHMITA SOM     |  |  |  |
|  |  | SAGUFTA PARVEEN |  |  |  |
|  |  | KAVITA SHARMA   |  |  |  |
|  |  | SWEETY KUMARI   |  |  |  |
|  |  | ARUNIMA CHANDRA |  |  |  |
|  |  | RANI SHARMA     |  |  |  |
|  |  | NASRIN KHATUN   |  |  |  |
|  |  | IPSITA DAS      |  |  |  |
|  |  | SAMMA KHATUN    |  |  |  |
|  |  | SUJATA BHASKAR  |  |  |  |
|  |  | DIPTI RAY       |  |  |  |
|  |  | PRITI SHA       |  |  |  |
|  |  | SWAGATA ADDYA   |  |  |  |
|  |  | TASLIMA KHATUN  |  |  |  |
|  |  | NILUFA KHATUN   |  |  |  |
|  |  | SAIYEDA KHATUN  |  |  |  |
|  |  | SALMA KHATUN    |  |  |  |
|  |  | SUSMITA GHOSH   |  |  |  |
|  |  | PIU DAS         |  |  |  |
|  |  | KOYEL DAS       |  |  |  |
|  |  | SOMA DAS        |  |  |  |
|  |  | NIDHI GUPTA     |  |  |  |
|  |  | PIU KOLEY       |  |  |  |
|  |  | RANJANA SHAW    |  |  |  |
|  |  | RUQAIYA KHATOON |  |  |  |

|  |                           |  |  |  |
|--|---------------------------|--|--|--|
|  | SIMRAN PRASAD             |  |  |  |
|  | SANJU KUMARI YADAV        |  |  |  |
|  | SABITA KUMARI YADAV       |  |  |  |
|  | RIMA KHATOON              |  |  |  |
|  | NEHA KUMARI YADAV         |  |  |  |
|  | SNEHA BARMAN              |  |  |  |
|  | SHAHINA BANO              |  |  |  |
|  | JYOTI KUMARI<br>CHOURASIA |  |  |  |
|  | PANKAJINI BARIK           |  |  |  |
|  | RUPSHA DAS                |  |  |  |
|  | SANGITA BAG               |  |  |  |
|  | SREEJEETA MUKHERJEE       |  |  |  |
|  | TRİYASHA DEY              |  |  |  |
|  | PRNOTI PAL                |  |  |  |
|  | ARCHANA SINGH             |  |  |  |
|  | NEHA JAISWAL              |  |  |  |
|  | SHAMA KHATOON             |  |  |  |
|  | NOOR SABA                 |  |  |  |
|  | TASNIMA ARA               |  |  |  |
|  | MOUSUMI DEY               |  |  |  |
|  | DEBIKA BHANDARI           |  |  |  |
|  | RUPSHA KANGSABANIK        |  |  |  |
|  | RESHMA KHATOON            |  |  |  |
|  | ANCHAL KUMARI OJHA        |  |  |  |
|  | RUBY KUMARI JHA           |  |  |  |
|  | PURBASHA NASKAR           |  |  |  |
|  | PUJA BHUIMALI             |  |  |  |
|  | SUSHMA MONDAL             |  |  |  |
|  | ARPITA MALIK              |  |  |  |

|  |                  |  |  |
|--|------------------|--|--|
|  | SUPRITI HALDAR   |  |  |
|  | SNIGDHA KARAK    |  |  |
|  | JUHI CHOUDHARY   |  |  |
|  | SNEHA BAG        |  |  |
|  | RIYA MALIK       |  |  |
|  | DIPTI MALIK      |  |  |
|  | TANIYA BAG       |  |  |
|  | TIYASA NASKAR    |  |  |
|  | SHREYA PATRA     |  |  |
|  | URMILA BHUIYA    |  |  |
|  | SIYA BISWAS      |  |  |
|  | MOUSUMI SARKAR   |  |  |
|  | LEENA BAG        |  |  |
|  | SWEETY MAJHI     |  |  |
|  | ARPITA MONDAL    |  |  |
|  | PUJA DHAKI       |  |  |
|  | SHREYA KHAN      |  |  |
|  | TRİYASHA ROY     |  |  |
|  | SOIJANYA KAYAL   |  |  |
|  | PUJA PATRA       |  |  |
|  | KAJAL RAJ MAJHI  |  |  |
|  | SANJITA BRAHMA   |  |  |
|  | LIPIKA MAJHI     |  |  |
|  | SUMITA GHORUI    |  |  |
|  | AVANTIKA BISWAL; |  |  |
|  | ANURIA BISWAS    |  |  |
|  | SWAPNA MALIK     |  |  |
|  | PAYEL PAIK       |  |  |
|  | ANWESHA HOWLADAR |  |  |
|  | RITIKA DHARA     |  |  |

|  |  |                     |  |  |  |
|--|--|---------------------|--|--|--|
|  |  | MANASI SANTRA       |  |  |  |
|  |  | RAKHI KUMARI PRASAD |  |  |  |
|  |  | ANKITA MONDAL       |  |  |  |
|  |  | JAYA MAL            |  |  |  |
|  |  | ANINDITA DAS        |  |  |  |
|  |  | RIYA KARAK          |  |  |  |
|  |  | SANJANA MALIK       |  |  |  |
|  |  | PRIYA BAG           |  |  |  |
|  |  | SANCHITA HAZRA      |  |  |  |
|  |  | SATHI KAL           |  |  |  |
|  |  | PAYEL SHAW          |  |  |  |
|  |  | PALLABI GHOSH       |  |  |  |
|  |  | SUPRITI GHOSH       |  |  |  |
|  |  | AYASA KHATUN        |  |  |  |
|  |  | PRIYA DHOLEY        |  |  |  |
|  |  | JHUMA PAUL          |  |  |  |
|  |  | ISHITA DAS          |  |  |  |
|  |  | PRITI SHAW          |  |  |  |
|  |  | SREYA PAL           |  |  |  |
|  |  | SANCHITA KARMAKAR   |  |  |  |
|  |  | SRABANI KARMAKAR    |  |  |  |
|  |  | KOYEL PAL           |  |  |  |
|  |  | PIUPA MODAK         |  |  |  |
|  |  | MUSKAN KHATOON      |  |  |  |
|  |  | RUMI PAL            |  |  |  |
|  |  | BARNALI GHOSH       |  |  |  |
|  |  | MALABIKA NARU       |  |  |  |
|  |  | SUCHETANA GHOSH     |  |  |  |
|  |  | DISHA GHOSH         |  |  |  |

|  |                             |  |  |
|--|-----------------------------|--|--|
|  | ASHMA KHATOON               |  |  |
|  | PURBASHA PAUL               |  |  |
|  | SANJANA PAL                 |  |  |
|  | KASHIBA PARVEEN             |  |  |
|  | NAINA GUPTA                 |  |  |
|  | SANIA KHATUN                |  |  |
|  | FARZANA KHATOON             |  |  |
|  | ROOKSANA KHATUN             |  |  |
|  | JEBA SOBHAN KHATUN          |  |  |
|  | HASIFA KHATUN               |  |  |
|  | RONGINA KHATUN              |  |  |
|  | ISRAT PARVEEN               |  |  |
|  | ALISA PARVEEN               |  |  |
|  | FARHANA KHATUN              |  |  |
|  | TAMANNA TABASSUM<br>KHATOON |  |  |
|  | SAISHTA TABASSUM            |  |  |
|  | DARAKHSHAN NOORIE           |  |  |
|  | JULFA KHATUN                |  |  |
|  | KAHKASHA PARVEEN            |  |  |
|  | MOSAMMAD SAHINA<br>KHATUN   |  |  |
|  | TUHINA PARVIN               |  |  |
|  | SIMRAN KHATUN               |  |  |
|  | NEGAR PARVEEN               |  |  |
|  | NAZRA PARVEEN               |  |  |
|  | SHABA NAZ                   |  |  |
|  | MOHOTARA YASMIN             |  |  |
|  | FAREEN GULSHAN              |  |  |
|  | ESMAT PARVEEN               |  |  |

|  |                    |  |  |  |
|--|--------------------|--|--|--|
|  | SAJDA KHATOON      |  |  |  |
|  | NEHA PARVEEN       |  |  |  |
|  | AFRIN KHATUN       |  |  |  |
|  | SHAHIN PARVEEN     |  |  |  |
|  | SABIYA KHATOON     |  |  |  |
|  | SIMA KHATOON       |  |  |  |
|  | SABANA PARWEEN     |  |  |  |
|  | FARIDA KHATOON     |  |  |  |
|  | KHAHCASHA PARVEEN  |  |  |  |
|  | NASRIN KHATOON     |  |  |  |
|  | SABA FIRDOUS       |  |  |  |
|  | ROSHAN PARVEEN     |  |  |  |
|  | SANA SOUFIA        |  |  |  |
|  | RUKHSAR            |  |  |  |
|  | MUSKAN KHATOON     |  |  |  |
|  | HASIBA KHATUN      |  |  |  |
|  | SHAJIYA PARVEEN    |  |  |  |
|  | SHREYA KUMARI      |  |  |  |
|  | SOUMOLI PARUI      |  |  |  |
|  | SAKSHI YADAV       |  |  |  |
|  | SHRUTI KUMARI      |  |  |  |
|  | SANJANA SARKAR     |  |  |  |
|  | SHERINA ALI MONDAL |  |  |  |
|  | SWARNALI PAL       |  |  |  |
|  | PALLABI DAS        |  |  |  |
|  | SATHI MITRA        |  |  |  |
|  | PIYASA KOLEY       |  |  |  |
|  | ARPITA DEBNATH     |  |  |  |
|  | ANKITA MONDAL      |  |  |  |
|  | KOMMANA PAVITRA    |  |  |  |

|                       |                  |                    |  |                        |   |
|-----------------------|------------------|--------------------|--|------------------------|---|
|                       |                  | GUNGUN MISHRA      |  |                        |   |
|                       |                  | PUJA SHEE          |  |                        |   |
|                       |                  | KOYAL BARIK        |  |                        |   |
|                       |                  | SUPRIYA DEYASE     |  |                        |   |
|                       |                  | ISHA SHAW          |  |                        |   |
|                       |                  | NEHA SINGH         |  |                        |   |
|                       |                  | KEYA RUIDAS        |  |                        |   |
|                       |                  | SUDIPTA DEBNATH    |  |                        |   |
|                       |                  | PRAPTI DAS         |  |                        |   |
|                       |                  | TITAS GHOSH        |  |                        |   |
|                       |                  | DISHA GHOSH        |  |                        |   |
|                       |                  | SUBHRA SADHUKHAN   |  |                        |   |
| ENVIRONMENTAL STUDIES | AECC 2 (General) | ALEYA KHATUN       | Serampore Girls' College,<br>WEST BENGAL | 6 months ( 1 semester) | <a href="https://seramporegirlscollege.org/main/site/Naac/view/5">https://seramporegirlscollege.org/main/site/Naac/view/5</a> |
|                       |                  | ANANDITA TATWA     |  |                        |   |
|                       |                  | ANISHA MUKHERJEE   |  |                        |   |
|                       |                  | ANKITA MAITI       |  |                        |   |
|                       |                  | ANTINA MUKHERJEE   |  |                        |   |
|                       |                  | ANUSHMITA KARAK    |  |                        |   |
|                       |                  | APARNA MALIK       |  |                        |   |
|                       |                  | ARUNIMA GHOSH      |  |                        |   |
|                       |                  | DEBASHREE SAREN    |  |                        |   |
|                       |                  | DEBI SHARMA        |  |                        |   |
|                       |                  | DEEPTIKA KARMAKAR  |  |                        |   |
|                       |                  | HIYA ORAON         |  |                        |   |
|                       |                  | INDRANI GHOSH      |  |                        |   |
|                       |                  | JAYITA SADHUKHAN   |  |                        |   |
|                       |                  | JUI SHIL           |  |                        |   |
|                       |                  | KOUSANY CHATTERJEE |  |                        |   |
|                       |                  | LAXMI MUDI         |  |                        |   |

|  |  |                      |  |  |  |
|--|--|----------------------|--|--|--|
|  |  | LIPIKA DUTTA         |  |  |  |
|  |  | MINAKHI PATRA        |  |  |  |
|  |  | MONALISA MISTERY     |  |  |  |
|  |  | NEHA HARI            |  |  |  |
|  |  | NISHA PAUL           |  |  |  |
|  |  | OYESHREE DHALI       |  |  |  |
|  |  | PAYEL DUTTA          |  |  |  |
|  |  | PRIYA DUTTA          |  |  |  |
|  |  | PRIYANKA PAL         |  |  |  |
|  |  | PRIYANKA SAHA        |  |  |  |
|  |  | RACHANA MANDAL       |  |  |  |
|  |  | RIMA GHOSH           |  |  |  |
|  |  | RIYA DAS             |  |  |  |
|  |  | RIYA DAS             |  |  |  |
|  |  | RIYA PAL             |  |  |  |
|  |  | RUPSHA MAN           |  |  |  |
|  |  | SAMATA DEY           |  |  |  |
|  |  | SANCHITA PAL         |  |  |  |
|  |  | SNEHA DAS            |  |  |  |
|  |  | SNEHA DEY            |  |  |  |
|  |  | SNEHA KOLEY          |  |  |  |
|  |  | SONALI GHOSH         |  |  |  |
|  |  | SUCHARITA KHAN       |  |  |  |
|  |  | SUPARNA MALIK        |  |  |  |
|  |  | SWASTIKA CHAKRABORTY |  |  |  |
|  |  | TANU MONDAL          |  |  |  |
|  |  | TANUSHRI DAS         |  |  |  |
|  |  | TUHINA DAS           |  |  |  |
|  |  | ANKITA DEBNATH       |  |  |  |
|  |  | ANUSHREE DUTTA       |  |  |  |
|  |  | ARPITA JHA           |  |  |  |

|  |  |                      |  |  |  |
|--|--|----------------------|--|--|--|
|  |  | POUSALI SARKAR       |  |  |  |
|  |  | RAJNI SINGH          |  |  |  |
|  |  | SUCHETA KUNDU        |  |  |  |
|  |  | SVETLANA MUKHERJEE   |  |  |  |
|  |  | ANUSHREE SANTRA      |  |  |  |
|  |  | ARCHANA KUMARI SINGH |  |  |  |
|  |  | ARPITA JANA          |  |  |  |
|  |  | BAISHAKHI GHOSH      |  |  |  |
|  |  | BARNALI CHAKRABORTY  |  |  |  |
|  |  | BILKIS KHATUN        |  |  |  |
|  |  | DISHA PAL            |  |  |  |
|  |  | DONA BAG             |  |  |  |
|  |  | ESA BODAK            |  |  |  |
|  |  | ISHANI DEBNATH       |  |  |  |
|  |  | JAYITA PARAMANICK    |  |  |  |
|  |  | KABERI SEN           |  |  |  |
|  |  | KAMALIKA JANA        |  |  |  |
|  |  | LATIKA KURUI         |  |  |  |
|  |  | LISHA PAUL           |  |  |  |
|  |  | MOUMITA BAKULI       |  |  |  |
|  |  | MOUMITA MAITY        |  |  |  |
|  |  | NEHA DUTTA           |  |  |  |
|  |  | NISHA RAVIDAS        |  |  |  |
|  |  | PONNA BHOWMIK        |  |  |  |
|  |  | POULAMI BAG          |  |  |  |
|  |  | PRATYASHA GHOSH      |  |  |  |
|  |  | PRITHA MRIDHA        |  |  |  |
|  |  | PRITY KUMAR MAHATO   |  |  |  |
|  |  | PRIYA GHOSH          |  |  |  |
|  |  | PRIYANKA MAHATO      |  |  |  |
|  |  | PUNAM UPADHYAY       |  |  |  |

|  |                     |  |  |
|--|---------------------|--|--|
|  | RAHOMOTI KHATUN     |  |  |
|  | RIMA HAZRA          |  |  |
|  | RIPTI DAS           |  |  |
|  | RIYA PAUL           |  |  |
|  | RIYA SIKDAR         |  |  |
|  | RUPSA GHOSH         |  |  |
|  | RUPSA MONDAL        |  |  |
|  | SATHI ROY           |  |  |
|  | SHATAVISHA BANERJEE |  |  |
|  | SHRESTHA CHATTERJEE |  |  |
|  | SHREYA GHOSH        |  |  |
|  | SILPI MITRA         |  |  |
|  | SNEHA PAUL          |  |  |
|  | SNEHA SAHA          |  |  |
|  | SORMISTRA MONDAL    |  |  |
|  | SOUMI GHOSH         |  |  |
|  | SUDESHNA GHOSH      |  |  |
|  | SUKANYA DAS         |  |  |
|  | SUMANA PANDIT       |  |  |
|  | SWAGATA HAZRA       |  |  |
|  | TIASA DEB           |  |  |
|  | TINA DUTTA          |  |  |
|  | TINA SANTRA         |  |  |
|  | TITHI KHAN          |  |  |
|  | TITLI DAS           |  |  |
|  | AFREEN ANSARI       |  |  |
|  | AFRIN KHATOON       |  |  |
|  | ANANYA ADAK         |  |  |
|  | ANKITA DAS          |  |  |
|  | ANTARA HALDER       |  |  |
|  | ARPITA MONDAL       |  |  |

|  |                     |  |  |
|--|---------------------|--|--|
|  | BEDISHA DEY         |  |  |
|  | DARAKHSHAN IFTEKHAR |  |  |
|  | DHATRI BISWAS       |  |  |
|  | DIPANWITA BISWAS    |  |  |
|  | DIYA DAS            |  |  |
|  | DONA KARMAKAR       |  |  |
|  | ISHITA DAS          |  |  |
|  | KOYEL ROY           |  |  |
|  | KULSUMA KHATUN      |  |  |
|  | LAEBA NOOR          |  |  |
|  | LOPAMUDRA JAISWAL   |  |  |
|  | MASHKURATUN NAMIRA  |  |  |
|  | MEGHA GIRI          |  |  |
|  | MOUPIRYA BHUL       |  |  |
|  | MOUSUMI PATRA       |  |  |
|  | MUSKAN KHATOON      |  |  |
|  | PALLAVI CHOUDHARY   |  |  |
|  | PRAKITI DAS         |  |  |
|  | PRITI KUMARI SHAW   |  |  |
|  | PRITI KUMARI YADAV  |  |  |
|  | RITOJA DEY          |  |  |
|  | RIYA DHARA          |  |  |
|  | RUMA BANDURI        |  |  |
|  | SAHELI GHOSH        |  |  |
|  | SAMRIDDHI SARKAR    |  |  |
|  | SARMIN YEASMIN      |  |  |
|  | SAYANI DAS          |  |  |
|  | SAYANTI DAS         |  |  |
|  | SHOAIBA SHAMIM      |  |  |
|  | SHREYA ROY          |  |  |
|  | SNEHA DAS           |  |  |

|  |                    |  |  |
|--|--------------------|--|--|
|  | SNEHA DOLUI        |  |  |
|  | SNEHA SARKAR       |  |  |
|  | SOUMILI MANDAL     |  |  |
|  | SUDIPTA GHOSH      |  |  |
|  | SUMAN SHAW         |  |  |
|  | SUNANDA SHAW       |  |  |
|  | SWASTIKA KARMAKAR  |  |  |
|  | TANAYA GHOSH       |  |  |
|  | TANUSHREE KUMAR    |  |  |
|  | TINA MALIK         |  |  |
|  | TIYASA PAUL        |  |  |
|  | ADITI BAG          |  |  |
|  | AHANA DUTTA        |  |  |
|  | ANANYA DAS         |  |  |
|  | ANKITA CHAKRABORTY |  |  |
|  | ANTARA GHANTA      |  |  |
|  | APARNA PAL         |  |  |
|  | ARPITA MALIK       |  |  |
|  | JAYASHREE GHOSH    |  |  |
|  | KOMAL SHARMA       |  |  |
|  | KOYEL KARMAKAR     |  |  |
|  | KOYEL KHAN         |  |  |
|  | MUNMUN GHOSH       |  |  |
|  | NAJIYA KALIM       |  |  |
|  | NASIMA KHATOON     |  |  |
|  | NISHA PAL          |  |  |
|  | PRIYA PAL          |  |  |
|  | PURNIMA SAHANI     |  |  |
|  | RESHMA KHATUN      |  |  |
|  | RIYA BAG           |  |  |
|  | RUBI MONDAL        |  |  |

|  |                            |  |  |
|--|----------------------------|--|--|
|  | SAHELI DAS                 |  |  |
|  | SAHINA SULTANA             |  |  |
|  | SANA PARWEEN               |  |  |
|  | SAYANI HALDER              |  |  |
|  | SAYANTIKA DAS              |  |  |
|  | SAYANTIKA DEY              |  |  |
|  | SEEMI PARWEEN              |  |  |
|  | SNEHA SHAW                 |  |  |
|  | SNEHASHREE<br>SADHUKHAN    |  |  |
|  | SONALI SADHUKHAN           |  |  |
|  | SUDESHNA AUDDY             |  |  |
|  | SUDESHNA SANTRA            |  |  |
|  | SUMANA SARKAR              |  |  |
|  | SUSMITA PAKHIRA            |  |  |
|  | TITHI KOLEY                |  |  |
|  | AMBARI NESA                |  |  |
|  | ASMA KHATUN                |  |  |
|  | BIDISHA SARKAR             |  |  |
|  | DEBLEENA SARKAR            |  |  |
|  | DEBOSMITA<br>BHATTACHARJEE |  |  |
|  | DIYA DEY                   |  |  |
|  | JASMINE NEGAR              |  |  |
|  | JAYEETA SARDAR             |  |  |
|  | KAINAT ANJUM               |  |  |
|  | KAJAL DALUI                |  |  |
|  | KANCHAN MALI               |  |  |
|  | KUMKUM CHOUDHARY           |  |  |
|  | LABANI PATRA               |  |  |
|  | MANDIRA MALIK              |  |  |
|  | NAGMA PARVEEN              |  |  |

|  |                          |  |  |
|--|--------------------------|--|--|
|  | NESHA RAJAK              |  |  |
|  | NIKHAT NISHAT            |  |  |
|  | PALLAVY CHOUDHARY        |  |  |
|  | PRAGATI KUMARI GUPTA     |  |  |
|  | PRITI PARUI              |  |  |
|  | PRIYA HAZRA              |  |  |
|  | RIMI DAS                 |  |  |
|  | RIYA BHATAK              |  |  |
|  | RUPA DAS                 |  |  |
|  | SAHANA KHATUN            |  |  |
|  | SAKHAWAT NARGIS<br>BEGUM |  |  |
|  | SARASWATI SARDAR         |  |  |
|  | SARNALI DAS              |  |  |
|  | SAYANI MONDAL            |  |  |
|  | SHAJAHAN KHATOON         |  |  |
|  | SHILPA MANNA             |  |  |
|  | SHRABANI PATRA           |  |  |
|  | SNEHA SANTRA             |  |  |
|  | SOUBARNI SIKDER          |  |  |
|  | SUBHAMITA GHOSH          |  |  |
|  | SUKANYA DAS              |  |  |
|  | SUMAN KUMARI YADAV       |  |  |
|  | SUNITA DAS               |  |  |
|  | SUNITA NAYAK             |  |  |
|  | SUSHMITA GHOSH           |  |  |
|  | SUSMITA MUKHERJEE        |  |  |
|  | SUSMITA PAKIRA           |  |  |
|  | SWETA KUMARI YADAV       |  |  |
|  | ANANYA CHAKRABORTY       |  |  |
|  | DISHA KARMAKAR           |  |  |

|  |                          |  |  |
|--|--------------------------|--|--|
|  | KOYEL DAS                |  |  |
|  | KOYEL DAS                |  |  |
|  | KUHELI DEY               |  |  |
|  | MAHIMA TIWARI            |  |  |
|  | NANDITA BHIR             |  |  |
|  | PUJA HATI                |  |  |
|  | PUJA MAJHI               |  |  |
|  | RAJESWARI KARMAKAR       |  |  |
|  | SAHELI GHOSH             |  |  |
|  | SARNALI GHOSH            |  |  |
|  | SHILPA PAL               |  |  |
|  | SHREYASI MANNA           |  |  |
|  | SNEHA DEY                |  |  |
|  | SNEHA TANTI              |  |  |
|  | TAMOSHA ROY<br>CHOWDHURY |  |  |
|  | ANWESHA GHOSH            |  |  |
|  | CHANDNI SHAW             |  |  |
|  | DEBASMITA SINGHA         |  |  |
|  | DIPA BANERJEE            |  |  |
|  | DIPIKA KUMARI THAKUR     |  |  |
|  | DIVYA KUMARI             |  |  |
|  | FARHAT NAAZ              |  |  |
|  | FARHAT PARVEEN           |  |  |
|  | GAYATRI MANDAL           |  |  |
|  | ISHIKA SANTRA            |  |  |
|  | J VANI KUMARI            |  |  |
|  | JASMIN JAHA              |  |  |
|  | KASHIS SHAW              |  |  |
|  | KHUSHBU KHATOON          |  |  |
|  | KHUSHBU KUMARI SINGH     |  |  |

|  |                     |  |  |
|--|---------------------|--|--|
|  | KIRAN MAHATO        |  |  |
|  | MANISHA SANTRA      |  |  |
|  | MOULINA CHAKRABORTY |  |  |
|  | MOZAHIDA TABASSUM   |  |  |
|  | NAGMA PARVEEN       |  |  |
|  | NEYAF PARVEEN       |  |  |
|  | PIU SHAW            |  |  |
|  | PRITIKANA ROY       |  |  |
|  | PURBA SANTRA        |  |  |
|  | QAYSAR JAHAN        |  |  |
|  | RASHMITA BEHERA     |  |  |
|  | RIMA DAS            |  |  |
|  | RINI BISWAS         |  |  |
|  | RITHIKA KARMAKAR    |  |  |
|  | RIYA SHAW           |  |  |
|  | ROOPKATHA SINHA     |  |  |
|  | RUPALI PRASAD       |  |  |
|  | SABA PARVEEN        |  |  |
|  | SABITA ROY          |  |  |
|  | SAHANA PARVEEN      |  |  |
|  | SAMA PARVEEN        |  |  |
|  | SANA NAZ            |  |  |
|  | SANA PARWEEN        |  |  |
|  | SANA RAFAT          |  |  |
|  | SANGITA DAS         |  |  |
|  | SATABDI ADHIKARI    |  |  |
|  | SHABNAM PARWEEN     |  |  |
|  | SHARMILA MAJHI      |  |  |
|  | SHOVA DAS           |  |  |
|  | SNEHA KUMARI        |  |  |
|  | SRABANI DAW         |  |  |

|                            |           |                    |   |                        |   |
|----------------------------|-----------|--------------------|---|------------------------|---|
|                            |           | TAMALI KOLEY       |   |                        |   |
|                            |           | TANUSREE HALDER    |   |                        |   |
|                            |           | ANISHA MANNA       |   |                        |   |
|                            |           | ANITA AHIRI        |   |                        |   |
|                            |           | BAISHAKHI PAL      |   |                        |   |
|                            |           | BITHIKA SARKAR     |   |                        |   |
|                            |           | CHANDRIMA PATRA    |   |                        |   |
|                            |           | DEBAPRIYA KOLE     |   |                        |   |
|                            |           | LAKSHMI MONDAL     |   |                        |   |
|                            |           | MALLIKA DAS        |   |                        |   |
|                            |           | MONISHA DAS        |   |                        |   |
|                            |           | RITU DEY           |   |                        |   |
|                            |           | ROBINA GHOSH       |   |                        |   |
|                            |           | SANKHAONI DAS      |   |                        |   |
|                            |           | SONALI DAS         |   |                        |   |
|                            |           | SWATHI SAMANTA     |   |                        |   |
|                            |           | SULAGNA CHATTERJEE |   |                        |   |
|                            |           | ANUSHREE DAS       |   |                        |   |
|                            |           | SNEHA PALIT        |   |                        |   |
|                            |           | SUMAN KUMARI GUPTA |   |                        |   |
| SANSKRIT HONOURS<br>SEM VI | SANA CC14 | RIYA PAL           | Serampore<br>Girls' College,<br>WEST BENGAL | 6 months ( 1 semester) | <a href="https://seramporegirlscollege.org/main/site/Naac/view/5">https://seramporegirlscollege.org/main/site/Naac/view/5</a> |
|                            |           | PAYEL PAL          |   |                        |   |
|                            |           | RIYA NANDI         |   |                        |   |
|                            |           | TUHELI BAR         |   |                        |   |
|                            |           | PRIYANKA DUTTA     |   |                        |   |
|                            |           | MAYABOTI KUNDU     |   |                        |   |
|                            |           | LALITA BHAR        |   |                        |   |
|                            |           | DEBOSMITA DUTTA    |   |                        |   |
|                            |           | SAYANI DUTTA       |   |                        |   |

|  |  |                           |  |  |  |
|--|--|---------------------------|--|--|--|
|  |  | PRITIKA DEY               |  |  |  |
|  |  | ASRIN KHATUN              |  |  |  |
|  |  | TANUSHREE<br>BHATTACHARYA |  |  |  |
|  |  | NEHA MAL                  |  |  |  |
|  |  | TIYASA SANTRA             |  |  |  |
|  |  | PUJA DOLUI                |  |  |  |
|  |  | RITUPARNA SARDAR          |  |  |  |
|  |  | JOTIRMOYEE SARDAR         |  |  |  |
|  |  | PANCHUMI BISWAS           |  |  |  |
|  |  | PUJA BAG                  |  |  |  |
|  |  | AISHWARYA DAS             |  |  |  |

**Project work/field work/ internships**  
**Name of Course: Achieves and Museums Code: SEC A (1)**  
**DEPT: HISTORY**  
**2022-2023**

## CRITERIA 1.3.2



## Serampore Girls College

13, T.C. Goswami Street,  
Serampore, Hooghly – 712201, West Bengal  
Re- Accredited by NAAC : Grade B (2nd Cycle)  
Email: [serampore\\_girls\\_college@yahoo.co.in](mailto:serampore_girls_college@yahoo.co.in)  
Website: [www.seramporegirlscollege.org](http://www.seramporegirlscollege.org)

# Serampore Girls' College

13, T.C. Goswami Street Serampore Hooghly - 712201 West Bengal

## NAAC Criteria 1.3.2



## FIELD VISIT REPORT 2022-2023

### REPORT ON FIELD WORK and WORKSHOP

**Department: HISTORY**

**Academic Session: 2022-2023**

**SEMSTER: III (HONS)**

**Name of Course: Achieves and Museums**

**Code: SEC A (1)**

**Location: Danish Govt House, Serampore Hooghly**

**Course Objective:**

Students will learn

- Practical knowledge on archives and Museums
- Vast information about the establishment of heritage city of Serampore
- Intra department collaboration

**Date:** JULY 2022-DEC 2022

**Duration:** 20 hours

**No of Students participated:** 81

**Name of Teachers:**

- i. Sk Riajul Midde (Assistant Professor, Dept of History , Serampore Girls' College)
- ii. Dr. Meghalai Lama (Assistant Professor, Dept of History , Serampore Girls' College)

**Course Outcome:**

- Requirement of Calcutta University (affiliating university) syllabus fulfilled
- students learned what is archives and Museums
- How to preserve any historical documents in a archives and Museums
- Also learned what is the documentation process in a achieve.

HOD Dept of History, Serampore Girls' College

*Soma Roy.*  
Principal  
Serampore Girls' College  
Serampore, Hooghly

Signature of Principal



Field Visit: at Danish Governor House, Serampore, Hooghly, Date: 24/11/2022

Paper: SEC A(1): Archives and Museum

### Skill Enhancement Courses (SEC –A & B) Credits,-2 each

#### SEC –A (1): Archives and museums

This course introduces students to the institutions that house and maintain documentary, visual and material remains of the past. Museums and archives are among the most important such repositories and this course explains their significance and how they work. Students will be encouraged to undertake collection, documentation and exhibition of such materials in their localities and colleges. Visit to National Archives and National Museum are an integral part of the course.

#### I. Definition and history of development (with special reference to India)

II. Types of archives and museums: Understanding the traditions of preservation in India  
Collection policies, ethics and procedures Collection: field exploration, excavation, purchase, gift and bequests, loans and deposits, exchanges, treasure trove confiscation and others. Documentation: accessioning, indexing, cataloguing, digital documentation and de-accessioning Preservation: curatorial care, preventive conservation, chemical preservation and restoration

#### III. Museum Presentation and Exhibition:

IV. IV. Museums, Archives and Society: (Education and communication Outreach activities

#### Essential Readings:

- Agrawal, O.P., Essentials of Conservation and Museology, Sundep Prakashan, New Delhi, India, 2007.  
Choudhary, R.D. Museums of India and their maladies. Calcutta: Agam Kala Prakashan, New Delhi, 1998(In Bengali).  
Guha, Thakurta, Tapati, Monuments, Objects, Histories: Institution of Art in Colonial Post Colonial India, New York, 2004  
Kathpalia, Y. P. Conservation and Restoration of Archive Materials. UNESCO, 1973  
Mathur Saloni, India by Design: Colonial History and Cultural Display, University of California, 2007  
Nair, S.M. Bio-Deterioration of Museum Materials. 2011  
Roychowdhury, Madhuparna. Displaying India's Heritage : Archaeology and the Museum Movement in Colonial India. Delhi: Orient Blackswan 2015  
Sengupta, S. Experiencing History Through Archives. Delhi: Munshiram Manoharlal. 2004.

## Syllabus of the Course

# Serampore Girls' College

13, T.C. Goswami Street Serampore Hooghly - 712201 West Bengal

## NAAC Criteria 1.3.2

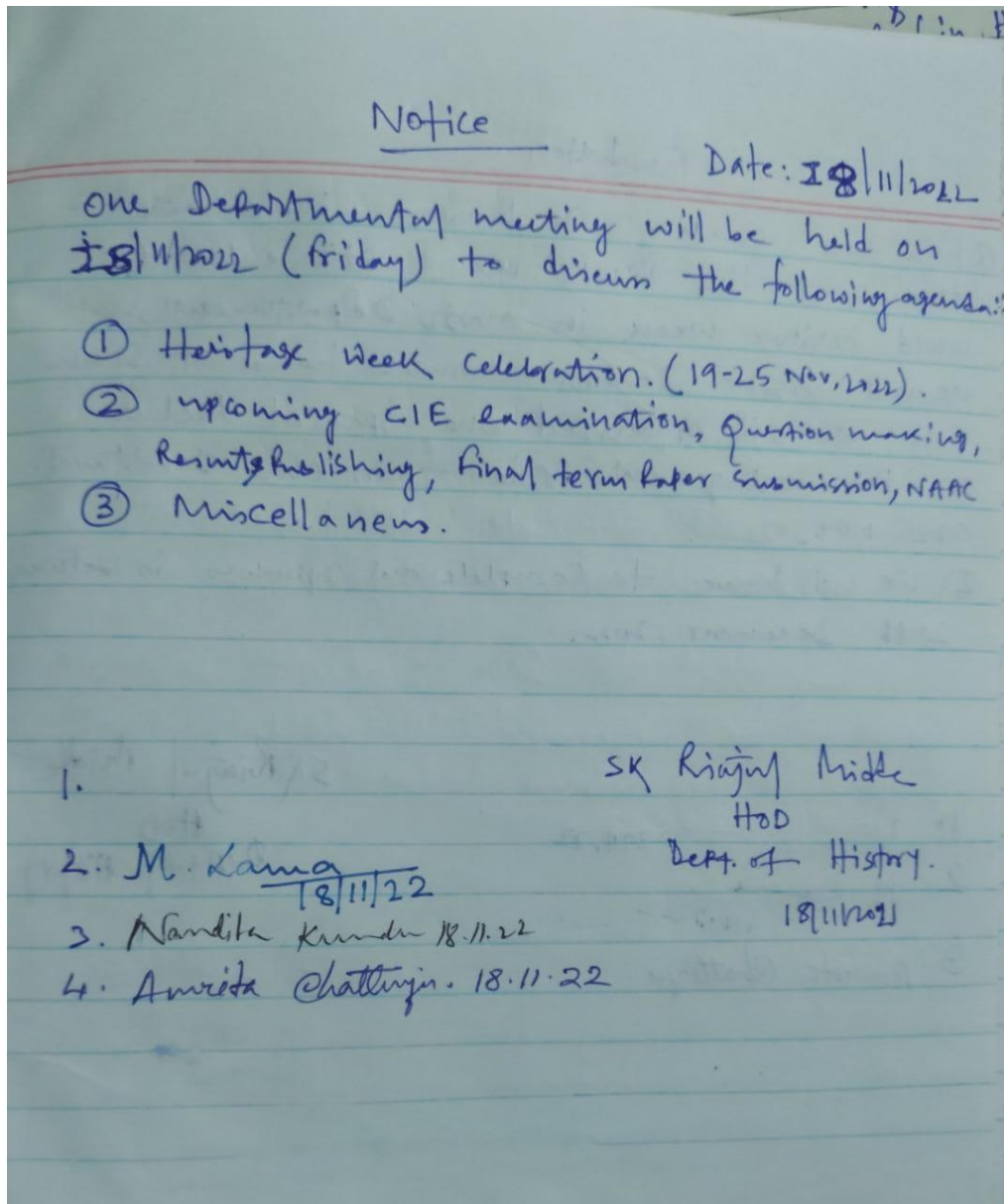

## Notice for The Field Visit

Soma Roy.  
Principal  
Serampore Girls' College  
Serampore, Hooghly

Signature of Principal

# Serampore Girls' College

13, T.C. Goswami Street Serampore Hooghly - 712201 West Bengal

## NAAC Criteria 1.3.2



Ph : (033) 26623723 (Office)

**Serampore Girls' College**  
(Estd.: 1981)  
Re-Accredited by NAAC : Grade B (2nd Cycle)  
13, T. C. GOSWAMI STREET, SERAMPORE, HOOGHLY, PIN-712 201, WEST BENGAL.  
E-mail : serampore\_girls\_college@yahoo.co.in  
Website : www.seramporegirlscollege.org

Ref. No. .... Date 24/11/22.

To  
The officer-in-charge,  
Dept. of Information and Culture,  
Governor's House, Serampore,  
Hooghly.

Sir,

on the occasion of world heritage week, 19th-25th  
November, the students of our college will visit  
the permanent exhibition in Governor's House,  
Serampore, Hooghly.

Please permit them to visit the exhibition.

Thanking you,  
Yours sincerely,  
Soma Roy,  
Principal  
Serampore Girls' College  
Serampore, Hooghly

সহকৃপা তথা কেন্দ্র, শ্রীরামপুর  
মহাকৃপা তথা ও সংস্কৃতি মন্ত্র  
শশিমঙ্গল সান্দাল  
24/11/22

Letter to Dept of Information and Culture from  
Principal of College

Soma Roy,  
Principal  
Serampore Girls' College  
Serampore, Hooghly

Signature of Principal

# Serampore Girls' College

13, T.C. Goswami Street Serampore Hooghly - 712201 West Bengal

## NAAC Criteria 1.3.2



Students World Heritage Week: celebration. (19th - 25th Nov, 22)  
 Signature: - visited Place: Janis Movement Home Date: 24/11/2022  
 Serampore, Hooghly. Time: 11-12:30 pm Day: Thursday.

| Name & Signature          | Dept. & Sem.   | College Roll | Experience:-     |
|---------------------------|----------------|--------------|------------------|
| 1. Chandrasree Chatterjee | HISA, 3rd Sem  | 21153        | Good             |
| 2. Riya Datta             | HISA, 3rd Sem  | 21175        | Good             |
| 3. Sanika Man             | HISA, 3rd Sem  | 21180        | Good             |
| 4. Sallu Sarda            | HISA, 3rd Sem  | 21182        | Good             |
| 5. Surishi Kumari Das     | HISA, 3rd Sem  | 21188        | Good             |
| 6. Dipa Karmas Rajak      | HISA, 3rd Sem  | 21154        | Good             |
| 7. Manira Bisoi           | HISA, 3rd Sem  | 21162        | Good             |
| 8. Megha Padwan.          | Sem 3rd, HISA  | 21163        | Good             |
| 9. Shabnam Rizwana        | HISA + 3rd Sem | 21183        | Interesting      |
| 10. Sumitra Kum. Shaw     | HISA, 3rd Sem  | 21147        | Good             |
| 11. Ritika choudhary      | HISA, 3rd Sem  | 21170        | Good             |
| 12. Jyoti Kumari          | HISA, 3rd Sem  | 21157        | Good             |
| 13. Karishma faswan       | HISA, 3rd Sem  | 21158        | Good             |
| 14. Neha Shaw             | HISA, 3rd Sem  | 21165        | Good             |
| 15. Anurika Chakraborty   | HISA, 3rd Sem  | 21148        | Very nice        |
| 16. Ipsita Mukherjee      | HISA, 3rd Sem  | 21155        | Good experience  |
| 17. Tiyaisha Bora         | HISA, 3rd Sem  | 21190        | Good             |
| 18. Priti Pal             | HISA, 3rd Sem  | 21190        | Good             |
| 19. Priti Sani            | HISA, 3rd Sem  | 21171        | Good             |
| 20. Swagata Ghosh.        | HISA, 3rd Sem  | 21189        | very nice        |
| 21. Pallabi Ghosh         | HISA, 3rd Sem  | 21168        | very Good        |
| 22. Shilpa Malik          | HISA, 3rd Sem  | 21184        | very good.       |
| 23. Barsha Das            | HISA, 3rd Sem  | 21150        | very good        |
| 24. Lisa Bora             | HISA, 3rd Sem  | 21159        | overall good.    |
| 25. Bidisha Ghosh         | HISA 3rd sem   | 21151        | Good             |
| 26. Amrita Mukherjee      | HISA 3rd Sem   | 21147        | Good             |
| 27. Ritika Paul           | HISA 3rd Sem   | 21173        | Good             |
| 28. Adwitia Ghosh         | HISA 3rd sem   | 21146        | Good             |
| 29. Sanghamita Bhunia     | HISA 2nd sem   | 21179        | very nice        |
| 30. Manon Roy             | HISA 3rd sem   | 21160        | Good             |
| 31. Mandira Roy           | HISA 3rd Sem   | 21161        | very nice        |
| 32. Pamela Roy            | HISA 3rd Sem   | 21169        | Good             |
| 33. Arati Shaw            | HISA 3rd Sem   | 21149        | Good experience. |
| 34. Divyis Saha           | HISA 3rd Sem   | 21152        | Good.            |
| 35. Riya Choudhary        | HISA 3rd Sem   | 21174        | Good experience  |
| 36. Sania Issac           | HISA 3rd sem   | 21181        | Good experience. |

## Students Feedback about the Field Visit

Soma Roy,  
Principal  
Serampore Girls' College  
Serampore, Hooghly

Signature of Principal

# Serampore Girls' College

13, T.C. Goswami Street Serampore Hooghly - 712201 West Bengal

## NAAC Criteria 1.3.2



Date: 24/11/2022

| Name & Signature           | Sem.           | Roll No | Experience |
|----------------------------|----------------|---------|------------|
| 1. Ritobrata Barua         | HISA First Sem | 22192   | Very Good  |
| 2. Bidisha Senkar          | HISA (1st Sem) | 22191   | Very Good  |
| 3. Beili Parui             | HISA (1st Sem) | 22208   | Very Good  |
| 4. Sunita Das              | HISA (1st Sem) | 22226   | Very Good  |
| 5. Sarani Das              | HISA (1st Sem) | 22216   | Very Good  |
| 6. Mandina Malik           | HISA (1st Sem) | 20202   | Very Good  |
| 7. Rimi Das                | HISA (1st Sem) | 22210   | Very Good  |
| 8. Saradwat Sarda          | HISA (1st Sem) | 22215   | Very Good  |
| 9. Shilpa monina           | HISA (1st Sem) | 22219   | Very Good  |
| 10. Anshamita Bhattacharya | HISA (1st Sem) | 22219   | Very Good  |
| 11. Sumita Mukherjee       | HISA (1st Sem) | 22229   | Very Good  |
| 12. Dina Das               | HISA (1st Sem) | 22194   | Very Good  |
| 13. Anubhava Das           | HISA (1st Sem) | 22220   | Very Good  |
| 14. Lakshmi Patra          | HISA (1st Sem) | 22202   | Very Good  |
| 15. Sayani Mandal          | HISA (1st Sem) | 22217   | Very Good  |
| 16. Sanika Nayak           | HISA (1st Sem) | 22227   | Very Good  |
| 17. Sebarani Saha          | HISA (1st Sem) | 22222   | Very Good  |
| 18. Riya Das               | HISA (1st Sem) | 22212   | Very Good  |
| 19. Jayesha Sarda          | HISA (1st Sem) | 22196   | Very Good  |
| 20. Snaha Santra           | HISA (1st Sem) | 22221   | Very Good  |
| 21. Sukanya Das            | HISA (1st Sem) | 22224   | Very Good  |
| 22. Sumatra Bhukta         | HISA (5th Sem) | 20200   | Very Good  |
| 23. Pooja Das              | HISA (5th Sem) | 20189   | Very Good  |
| 24. Reshita Oena           | HISA (5th Sem) | 20186   | Very Good  |
| 25. Sathi Pal              | HISA (5th Sem) | 20188   | Very Good  |
| 26. Trishna Patowari       | HISA (5th Sem) | 20202   | Very Good  |
| 27. Anami Bar              | HISA (5th Sem) | 20198   | Very Good  |
| 28. Anisha Khutun          | HISA (5th Sem) | 20161   | Very Good  |
| 29. Julekha Khutun         | HISA (5th Sem) | 20168   | Very Good  |
| 30. Ancharina Chakraborty  | HISA (5th Sem) | 20187   | Very Good  |
| 31. Ashmita Kauri Thakur   | HISA (5th Sem) | 20167   | Very Good  |
| 32. Shebana Prasen         | HISA (5th Sem) | 20185   | Nice       |

Date: 24/11/2022

|                       |              |       |                 |
|-----------------------|--------------|-------|-----------------|
| 12. Neha Rajbhar      | HISA 5th sem | 20177 | Best            |
| 13. Anu Choudhary     | HISA 5th sem | 20174 | Very Good       |
| 14. Sacha Das         | HISA 5th sem | 20198 | Very Good       |
| 15. Koyal Maitra      | HISA 5th Sem | 20170 | Very Good       |
| 16. Nabidee Saha      | HISA 5th Sem | 20203 | Very Good       |
| 17. Shaheen Parween   | HISA 5th Sem | 20190 | Good Experience |
| 18. Nishwani Halder   | HISA 5th Sem | 20179 | Good Experience |
| 19. Jona Kumari Das   | HISA 5th Sem | 20199 | Very Nice       |
| 20. Neha Kumari Das   | HISA 5th Sem | 20176 | Very Good       |
| 21. Simran Humani Das | HISA 5th Sem | 20194 | Very Nice       |
| 22. Sudeshna Pal      | HISA 5th sem | 20191 | Very Good       |
| 23. Pa Yek Das        | HISA 5th sem | 20205 | Very Good       |
| 24. Anshita Khan      | HISA 5th Sem | 20166 | Very Good       |
| 25. Anshree Roy       | HISA 5th Sem | 20162 | Nice            |

Prof: -  
 SK Kinjal Mitter, HOD, Asst. Prof. in History, 24/11/2022  
 Meghla Lama, Asst. Prof. in History, 24/11/2022  
 Subhanya Bhadra, Associate Prof. of English, 24/11/2022

### Students Feedback about the Field Visit

Soma Roy,  
Principal  
Serampore Girls' College  
Serampore, Hooghly

Signature of Principal

# Serampore Girls' College

13, T.C. Goswami Street Serampore Hooghly - 712201 West Bengal

## NAAC Criteria 1.3.2



**Hooghly, West Bengal, India**

Q84V+86F, Panchu Gopal Bhaduri Sarani, Serampore, West Bengal 712201, India

Lat 22.755918°

Long 88.343118°

24/11/22 12:13 PM GMT +05:30

GPS Map Camera



**Hooghly, West Bengal, India**

Q84V+76C, Panchu Gopal Bhaduri Sarani, Serampore, West Bengal 712201, India

Lat 22.755725°

Long 88.34309°

24/11/22 11:37 AM GMT +05:30

GPS Map Camera

Students photos during field visit at Danish Govt House

*Soma Roy*  
Principal  
Serampore Girls' College  
Serampore, Hooghly

Signature of Principal

**Project work/field work/ internships**  
**Name of Course: Art Appreciation: An introduction to Indian Art**  
**Code: SEC-B (2)**  
**DEPT: HISTORY**  
**2022-2023**

## **CRITERIA 1.3.2**



## **Serampore Girls College**

13, T.C. Goswami Street,  
Serampore, Hooghly – 712201, West Bengal  
Re- Accredited by NAAC : Grade B (2nd Cycle)  
Email: [serampore\\_girls\\_college@yahoo.co.in](mailto:serampore_girls_college@yahoo.co.in)  
Website: [www.seramporegirlscollege.org](http://www.seramporegirlscollege.org)

# Serampore Girls' College

13, T.C. Goswami Street Serampore Hooghly - 712201 West Bengal

## NAAC Criteria 1.3.2



## FIELD VISIT REPORT 2022-2023

### REPORT ON FIELD WORK

Department: HISTORY

Academic Session: 2022-2023

SEMSTER: IV (HONS)

**Name of Course: Art Appreciation: An introduction to Indian Art**

**Code: SEC-B (2)**

**Location: Serampore Rajbari, Serampore Hooghly**

**Course Objective:**

Students will learn

- Practical knowledge of British colonial Indian architecture.
- How to preserve any heritage architecture building

**Date:** Jan 2023-June 2023

**Duration:** 6 hours

**No of Students participated:** 58

**Name of Teachers:**

- Sk Riajul Midde (Assistant Professor, Dept of History , Serampore Girls' College)
- Dr. Meghalai Lama (Assistant Professor, Dept of History , Serampore Girls' College)
- Nandita Kundu (Associate Professor, Dept of History , Serampore Girls' College)
- Amrita Chatterjee (SACT Teacher Dept of History , Serampore Girls' College)

**Course Outcome:**

- Requirement of Calcutta University (affiliating university) syllabus fulfilled
- Students learned what is architecture and art.
- How to preserve any historical monuments.
- Practical knowledge about any heritage site.

HOD Dept of History, Serampore Girls' College

*Soma Roy,*  
Principal  
Serampore Girls' College  
Serampore, Hooghly

Signature of Principal

# Serampore Girls' College

13, T.C. Goswami Street Serampore Hooghly - 712201 West Bengal

## NAAC Criteria 1.3.2



Agrawal, O.P., Essentials of Conservation and Museology, Delhi, 2006

Chainani, S. 2007. Heritage and Environment. Mumbai: Urban Design Research Institute, 2007

### SEC –B (2): Art Appreciation: an Introduction to Indian Art

The purpose of this course is to introduce students to Indian art, from ancient to contemporary times, in order to understand and appreciate its diversity and its aesthetic richness. The course will equip students with the abilities to understand art as a medium of cultural expression. It will give students direct exposure to Indian art through visuals, and visits to sites and museums.

**I. Prehistoric and protohistoric art:** \_Rock art; Harappan arts and crafts

**II. Indian art (c. 600 BCE – 600 CE):**

World Heritage Site Managers, UNESCO World Heritage Manuals  
[Can be downloaded/ accessed at [www.unesco.org](http://www.unesco.org)]

Notions of art and craft Canons of Indian paintings Major developments in stupa, cave, and temple art and architecture Early Indian sculpture: style and iconography Numismatic art

**III. Indian Art (c. 600 CE – 1200 CE) :** Temple forms and their architectural features Early illustrated manuscripts and mural painting traditions Early medieval sculpture: style and iconography Indian bronzes or metal icons

**IV. Indian art and architecture (c. 1200 CE – 1800 CE) :**

Sultanate and Mughal architecture Miniature painting traditions: Mughal, Rajasthani, Pahari  
Introduction to fort, palace and haveli architecture

**V. Modern and Contemporary Indian art and Architecture:**

The Colonial Period Art movements: Bengal School of Art, Progressive Artists Group, etc.  
Major artists and their artworks Popular art forms (folk art traditions)

**Essential Readings**

Neumayer, Erwin, Lines of Stone: The pre-historic rock-art of India,  
South Asia Books, 1993  
Goswamy, B.N., Essence of Indian Art, Asian Art Museum of San  
Francisco, 1986

Huntington, Susan, The Art of Ancient India: Hindu, Buddhist, Jain, Weatherhill, 1985

Guha-Thakurta, Tapati, The making of a new modern Indian art: Aesthetics and nationalism in  
Bengal, 1850-1920, Cambridge University Press, 1992

**Suggested Readings:**

Mitter, Partha, Indian Art, Oxford History of Art series, Oxford University Press, 2001

Dhar, Parul Pandya, ed., 2011, Indian Art History Changing Perspectives, New Delhi: D.K.  
Printworld and National Museum Institute (Introduction).

Beach, M.C., The New Cambridge History of India I: 3, Mughal and Rajput Painting, Cambridge  
University Press, 1992.

Ray, Niharranjan, An Approach to Indian Art, Calcutta, 1970

53

## Calcutta University Syallabus of the Course

Soma Roy,  
Principal  
Serampore Girls' College  
Serampore, Hooghly

Signature of Principal

# Serampore Girls' College

13, T.C. Goswami Street Serampore Hooghly - 712201 West Bengal

## NAAC Criteria 1.3.2



**SERAMPORE GIRLS' COLLEGE**  
(Estd.- 1981)  
Accredited by : NAAC

**DEPARTMENT OF HISTORY**

13, T.C. Goswami, Serampore, Hooghly- 722201, West Bengal  
Email : serampore\_girls\_college@yahoo.co.in

---

Ref. No.: ..... Date: 26.04.2023

Notice

Subject: World Heritage day celebration, on 28th April, 2023.

Dear,  
Students on behalf of our Department I am going to inform you that our History Department and Heritage club jointly going to organize one field visit and workshop Programme on the event of 'World Heritage Day', at Serampore Rajbati, Hooghly. It will start from 11.30 a.m onwards.  
I am inviting you all to attend this important Programme.  
Thanking you.

Your faithfully  
SK Rajul Mitter  
HOD.  
Dept. of History

### Notice for the Field Visit by Head of Department

Soma Roy,  
Principal  
Serampore Girls' College  
Serampore, Hooghly

Signature of Principal

# Serampore Girls' College

13, T.C. Goswami Street Serampore Hooghly - 712201 West Bengal

## NAAC Criteria 1.3.2



" Field visit and workshop  
on the occasion of World Heritage Day "  
Place: "Serampur Rajbari"  
Date: 28/04/2023

| HISA 6th Sem students            |              |
|----------------------------------|--------------|
| Name & Roll no. :-               | Feedback     |
| 1. Neha Kumari Das (20176)       | very good.   |
| 2. Shaheen Parveen (20190)       | very good.   |
| 3. Simran Kumari Shaw (20194)    | Very good    |
| 4. Sima Kumari Shaw (20193)      | very nice.   |
| 5. Anushree Roy (20163)          | Good.        |
| 6. Arpita Khan (20166)           | Good.        |
| 7. Shobana Parveen (20189)       | Good         |
| 8. Anisha Khatter (20161)        | Good         |
| 9. Ashmita Kumari Thakur (20167) | Good         |
| 10. Nitu Kumari (20178)          | Good.        |
| 11. Neha Rajbhar (20177)         | Good.        |
| 12. Arpita Goidan (20185)        | v.v. good    |
| 13. Sudesma Tal (20199)          | very useful. |
| 14. Payel Bag (20705)            | very nice.   |
| 15. Priya Sharma (20181)         | very good    |
| 16. Puja Das (20184)             | very good    |
| 17. Sumatra Bhukta (20200)       | very good    |

Field Visit attendance cum feedback

Soma Roy,  
Principal  
Serampore Girls' College  
Serampore, Hooghly

Signature of Principal

# Serampore Girls' College

13, T.C. Goswami Street Serampore Hooghly - 712201 West Bengal

## NAAC Criteria 1.3.2



Field Visit and Workshop on the occasion of World Heritage Day.  
Place: Serampore Rajbari  
Date: 28/04/2023 Time: 11 am onwards.

HISA 4th Sem students

| Name & Roll No                    | Feedback  |
|-----------------------------------|-----------|
| 1. Chandrasree Chatterjee (21153) | Nice      |
| 2. Pallabi Ghosh (21168)          | Good      |
| 3. Swagata Ghosh (21189)          | very nice |
| 4. Priti Pal (21170)              | very nice |
| 5. Monisa Singha (21164)          | very good |
| 6. Sania Israat (21181)           | Good      |
| 7. Bilquis Saba (21152)           | Good      |
| 8. Riya Chowdhary (21174)         | Good      |
| 9. Shelanai Razaana (21183)       | Good      |
| 10. Dipa Kumari Rajak (21154)     | Good      |
| 11. Jyoti Kumari (21157)          | Good      |
| 12. Sanidhi Kumari Das (21188)    | Good      |
| 13. Kamishra Paswan (21158)       | Good      |
| 14. Adwitia Ghosh (21196)         | very nice |
| 15. Roshni Mondal (21177)         | Good      |
| 16. Nisha Dey (21167)             | Good      |
| 17. Lisa Bati (21159)             | Good      |
| 18. Amrita Mukherjee (21147)      | Good      |
| 19. Anshika Chakraborty (21148)   | Good      |
| 20. Pranita Majumdar (21155)      | Good      |
| 21. Neha Shaw (21165)             | Good      |
| 22. Barsha Das (21150)            | Good      |
| 23. Shilpa Malik (21184)          | Good      |
| 24. Ritika Paul (21173)           | Good      |
| 25. Sanghamita Bhowia (21179)     | Good      |
| 26. Mondira Roy (21161)           | Good      |
| 27. Mamon Roy (21160)             | Good      |
| 28. Bidisha Ghosh (21151)         | not bad   |
| 29. Rida Dhara (21175)            | not bad   |
| 30. Sangha man (21180)            | Good      |

Field Visit attendance cum feedback

Soma Roy,  
Principal  
Serampore Girls' College  
Serampore, Hooghly

Signature of Principal

# Serampore Girls' College

13, T.C. Goswami Street Serampore Hooghly - 712201 West Bengal

## NAAC Criteria 1.3.2



Field visit and workshop  
on the occasion of world heritage day.

Place: Serampore Rajbati,  
Date: 25/04/2023, Time: 11 a.m onwards.

HSA. 2nd Sem students (Attendees)  
Feedback.

| Name & Roll No                    | Feedback.  |
|-----------------------------------|------------|
| 1) Saraswati Sardar (22215)       | very good. |
| 2) Sayani Mondal (22217)          | very Nice  |
| 3) Sukanya Das (22224)            | Very good  |
| 4) Subhamita Ghosh (22225)        | nice       |
| 5) Nikhat Nishat (22205)          | Good.      |
| 6) Kumi Kum Choudhary (22200)     | Good       |
| 7) Susmita Mukherjee (22229)      | Good.      |
| 8) Debasmita Bhattacharya (22193) | Good.      |
| 9) Priya Hazra (22209)            | Good       |
| 10) Nayana Aarveem (22203)        | Very Good  |
| 11) Jayeeta Sardar (22196)        | Good       |

### Field Visit attendance cum feedback

Soma Roy.  
Principal  
Serampore Girls' College  
Serampore, Hooghly

Signature of Principal

# Serampore Girls' College

13, T.C. Goswami Street Serampore Hooghly - 712201 West Bengal

## NAAC Criteria 1.3.2



### Images during Field Visit at Serampore Rajbari

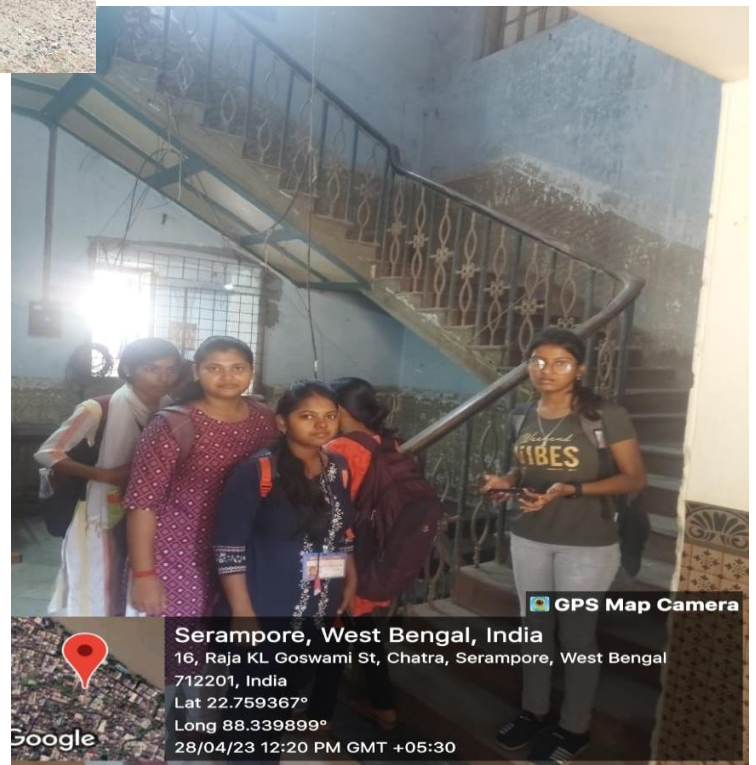

Soma Roy.  
Principal  
Serampore Girls' College  
Serampore, Hooghly

Signature of Principal

Project work/field work/ internships  
Name of Course: Report on Research Methodology and field work Lab  
Code: GEO-A-CC5-11-P  
DEPT: GEOGRAPHY  
2022-2023

# Criteria 1.3.2



## Serampore Girls College

13, T.C. Goswami Street,  
Serampore, Hooghly – 712201, West Bengal  
Re- Accredited by NAAC : Grade B (2nd Cycle)  
Email: [serampore\\_girls\\_college@yahoo.co.in](mailto:serampore_girls_college@yahoo.co.in)  
Website: [www.seramporegirlscollege.org](http://www.seramporegirlscollege.org)

# Serampore Girls' College

13, T.C. Goswami Street Serampore Hooghly - 712201 West Bengal

## NAAC Criteria 1.3.2



### FIELD VISIT REPORT 2022-2023

**Department: GEOGRAPHY**

**Academic Session: 2022-2023**

**SEMSTER: V (FIVE)**

**Name of Course: Report on Research Methodology and field work Lab**

**Code: GEO-A-CC5-11-P**

**Location: Mirik and Darjeeling, West Bengal**

#### **Course Objective:**

Students will learn

- To study the physio and socio economic status of selected wards in Mirik Municipality
- To find out the soil and water quality in the study area.
- To work out the different problem related to physio and demography in the study area.

**Date:** 15/09/2022 to 20/9/2022

**Duration:** 6 days

**students participated:** 31

#### **Name of Teachers:**

- Dr Asraful Alam (Teacher and HOD, Dept of Geogrpahy Serampore Girls' College) ,
- Tumpa Hudut (Teacher, Dept of Geogrpahy Serampore Girls' College)
- Priyanka Dey (Teacher, Dept of Geogrpahy Serampore Girls' College)

Assistant:

- Mr. Tarun Kr. Pal ( Lab Assistant, Dept of Geogrpahy Serampore Girls' College)

#### **Course Outcome:**

- In this field work students learned about the physio and socio economic status of selected wards in Mirik Municipality
- In this field work students learned about the soil and water quality in the study area
- In this field work students identified different problems from the field of physiography (undulating topography) , culture, population etc

HOD Dept of Geogrpahy, Serampore Girls' College

*Soma Roy.*  
Principal  
Serampore Girls' College  
Serampore, Hooghly

Signature of Principal

## Syllabus of the Course (Calcutta University)

### 2.22 GEO-A-CC-5-11-P – Research Methodology and Fieldwork Lab ✧ 30 Marks / 2 Credits

*Every student needs to participate in fieldwork and prepare a field report according to the following guideline, failing which he/she will not be evaluated for GEO-A-CC-5-11-P.*

1. Each student will prepare a report based on primary data collected from field survey and secondary data collected from different sources.
2. Students will select either one rural area (*mouza*) or an urban area (municipal ward) for the study, with the primary objective of evaluating the relation between physical and cultural landscape.
3. A specific problem or a special feature should be identified based on which, the study area will be selected.
4. The report should be handwritten in English on A4 size paper in candidate's own words within 5,000 words (Introductory Chapter: 1000 words; Physical Aspects: 1500 words; Socio-economic Aspects: 1500 words; Concluding Chapter: 500 words, approximately) excluding tables, photographs, maps, diagrams, references and appendices.
5. Photographs, maps and diagrams should not exceed 15 pages.
6. A copy of the bound report, duly signed by the concerned teacher, will be submitted during examination.
7. The field work and post-field work will include:
  - a. Collection of primary data on physical aspects (relief and soil) of the study area. Students should use survey instruments like prismatic compass, dumpy level, Abney level or clinometer wherever necessary.
  - b. Collection of soil samples from different land cover land use regions of the study area for determining pH and NPK values with help of a soil kit.
  - c. Collection of socio economic data, at the household level (with the help of a questionnaire) in the selected study area.
  - d. Plot to plot land use survey for preparation of a land use map, covering whole or part of the selected area.
  - e. Visit to different organisations and departments for collection of secondary data.
  - f. Any other survey relevant to the objective of the study.
8. The Field Report should contain the following sections (a–e).
  - a. Introduction: Study area extent and space relations, reasons for selection of the study area on the basis of a specific problem or special feature, objectives, methods of data collection, analyses and presentation, sources of information, etc.
  - b. Physical aspects: Lithology and geological structure, relief, slope, drainage, climate, soil, vegetation, environmental issues, proneness to natural hazards, etc.
  - c. Socio-economic aspects:
    - i. Population attributes: number, sex ratio, literacy, occupational structure, ethnic and religious composition, language, per capita income, etc.
    - ii. Settlement characteristics: Number of houses, building materials, number and size of rooms, amenities, etc.
    - iii. Agriculture: General land use, crop-combination, use of fertiliser and irrigational facilities, production and marketing etc.
    - iv. Other economic activities: Fishing, horticulture, brick-making, household and other industries, etc.

- d. Conclusions: Relation between physical and cultural landscape. Evaluation of problems and prospects. General recommendations.
  - e. Bibliography.
9. The students will prepare (i) a chorochromatic land use land cover map on the basis of plot to plot survey; (ii) a profile of 250–1000 m, surveyed and plotted, with different land use land cover superimposed on it.
  10. All sections of the report should contain relevant maps, diagrams and photographs using primary and secondary data, clearly citing sources.
  11. All surveys should pertain to the objective of the study. Surveys not relevant for establishing the relation between physical and cultural landscape should be avoided.
  12. Marks division: 20 on report + 10 on viva-voce = 30

# Serampore Girls' College

(Estd.: 1981)

Re-Accredited by NAAC : Grade B (2nd Cycle)

13, T. C. GOSWAMI STREET, SERAMPORE, HOOGHLY. PIN-712 201, WEST BENGAL.

E-mail : serampore\_girls\_college@yahoo.co.in

Website : www.seramporegirlscollege.org

Re

Ref. No. ....

Date .....

## Notice for the students from Principal about the field visit

To  
The Office In Charge  
Mirik Police Station  
Mirik, Darjeeling

Sir,

This is to inform you that 31 students of B.Sc. Geography Department under Graduation of this College along with Five Guide (teachers & Staff) are going to visit Mirik and Darjeeling for an educational tour and Socio economic survey from 15/09/2022 to 20/09/2022.

This is for your kind information and with request for necessary help if required.

Thanking You,

Yours Sincerely

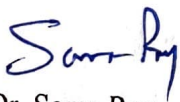

Dr. Soma Roy  
Principal  
Serampore Girls' College  
Serampore, Hooghly  
West Bengal, India

**Principal**  
**Serampore Girls' College**  
Serampore, Hooghly



# Department of Geography

## Serampore Girls' College

(Affiliated to the University of Calcutta)

### students details and tour schedule for the field visit

Date: 15/9/2022

Serdah to Darjeeling

Train time: 8:30 pm

#### Students Details for Educational Excursion

| Name of the Students | College Roll Number | Age | Signature of the Students with time (Date of joining 15/9/22) | Signature of the Student's Parents |
|----------------------|---------------------|-----|---|------------------------------------|
| Piyali Chandra       | 20328               | 19  | Piyali Chandra  |                                    |
| Sujata Kayal         | 20346               | 19  | Sujata Kayal  |                                    |
| SANJUKTA SHARMA      | 20709               | 20  | Sanjukta Sharma   |                                    |
| Manisha santra       | 20323               | 22  | Manisha Santra  |                                    |
| Priyanka Dalui       | 20330               | 19+ | Priyanka Dalui  |                                    |
| Priti Tatawa         | 20329               | 20  | Priti Tatawa  |                                    |
| Dishita De           | 20320               | 21  | Dishita De.<br>15/09/22.                                      |                                    |
| Soma Mondal          | 20342               | 20  | Soma Mondal   |                                    |
| Suparna Adhikary     | 20347               | 21  | Suparna Adhikary  |                                    |
| Arpita Malik         | 20317               | 20  | Arpita Malik  |                                    |
| Rinku Dey            | 20331               | 20  | Rinku Dey   |                                    |
| Soumini Dutta        | 20344               | 21  | Soumini Dutta   |                                    |
| Rupsha Dey           | 20332               | 20+ | Rupsha Dey  |                                    |

Soma Roy,  
Principal  
Serampore Girls' College  
Serampore, Hooghly

# Department of Geography

## Serampore Girls' College

(Affiliated to the University of Calcutta)

Pin Code - 712201, West Bengal, India

|     |                  |       |     |                          |
|-----|------------------|-------|-----|--------------------------|
| 14) | Saba Parween     | 20333 | 20  | Saba Parween.            |
| 15) | Aishwarya Roy    | 20314 | 20  | Aishwarya Roy            |
| 16) | Pallabi Majhi    | 20325 | 21  | Pallabi Majhi            |
| 17) | Soumi Dey        | 20343 | 18+ | Soumi Dey                |
| 18) | Barsha Nayak     | 20319 | 19+ | Barsha Nayak.            |
| 19) | Nibedita Das     | 20324 | 20  | <del>Sangita Koley</del> |
| 20) | Sangita Koley    | 20336 | 20  | Nibedita Das             |
| 21) | Shreya Ghosh     | 20338 | 20  | Shreya Ghosh             |
| 22) | Snehashree De    | 20341 | 19+ | Snehashree De            |
| 23) | Payel Pal        | 20327 | 21  | Payel Pal                |
| 24) | Shahin banu      | 20337 | 20  | Shahin Banu.             |
| 25) | Doniya pramanick | 20321 | 20  | Doniya pramanick.        |
| 26) | Sreya Ash        | 20345 | 20  | Sreya Ash                |
| 27) | Barsha Malik     | 20318 | 20  | Barsha Malik             |
| 28) | Sneha Tudu       | 20340 | 21  | Sneha Tudu.              |
| 29) | Ankita Chandra   | 20315 | 19+ | Ankita Chandra           |
| 30) | Sanchaita Das    | 20334 | 18  | Sanchaita Das            |
| 31) | Lisa Majumder    | 20322 | 21  | Lisa Majumder.           |

Soma Roy,  
Principal  
Serampore Girls' College  
Serampore, Hooghly

# Department of Geography

## Serampore Girls' College

(Affiliated to the University of Calcutta)

13, T.C. Goswami Street, Serampore, Hooghly - 712201, West Bengal, India

### Departmental Excursion

| Sl. No | Name of the Guardians with Date | Name of the Students with Date | UP/DN (Station)    | Remarks         |
|--------|---------------------------------|--------------------------------|--------------------|-----------------|
| 1      | Tharna Tudu 30/8/22             | Sreha Tudu 30/8/22             |                    |                 |
| 2      | Arpna Das,                      | Sanchaita Das<br>30/8/22       |                    |                 |
| 3      | Tapasi pramanick<br>30/8/22     | Doniya pramanick<br>30/8/22    | DN<br>- Kamarkundu |                 |
| 4      | Chhandika Dutta                 | Soumini Dutta<br>30.8.22       |                    |                 |
| 5      | Shree or tataa                  | Priiti Tatawa<br>30.08.22      |                    |                 |
| 6      | Nasima Khatoon                  | Saba Parween<br>30.8.22        |                    |                 |
| 7      | Samshu Nayak                    | Barsha Nayak                   |                    |                 |
| 8      | Mitali Pal                      | Payel Pal                      |                    |                 |
| 9      | সম্মিতা দেবী                    | পায়েল পাল                     | DN/Kamarkundu      |                 |
| 10     | Sadipa Adhikary                 | Saparna Adhikary               |                    | Kamarkundu      |
| 11     | Chantal de.<br>30.08.22         | Dishita De.                    |                    |                 |
| 12     | Samiya kumar                    | Soumi Dey                      |                    | Saba's guardian |
| 13     | Bahadur Mazhi                   | Pallabi Mazhi                  |                    | DN-Kamarkundu   |
| 14     | Swapan Kumar Ghosh              | Shroga Ghosh                   | DN-Burdwan         | Burdwan         |
| 15     | Jhuma Santra                    | Manisha Saha                   | DN-Kamarkundu      |                 |
| 16     | সুবর্ণা দাস                     | Bhyanika Das                   |                    |                 |

Soma Roy,  
Principal  
Serampore Girls' College  
Serampore, Hooghly

|    |                          |                |                 |  |
|----|--------------------------|----------------|-----------------|--|
| 17 | Bitika Malik<br>30.8.22  | Arpita Malik   | DN/Kamarkundu   |  |
| 18 | Manju Dey                | Rinku Dey      | DN/Kamarkundu   | আওতা -> নিবন্ধিত<br>অতিরিক্ত<br>আওতা -> অতিরিক্ত |
| 19 | Zainab Rashed            | Shahin Banu    |                 |  |
| 20 | Lipika Banerjee          | Lisa Meher     |                 |  |
| 21 | Dipali Chandra           | Piyali Chandra | DN - Kamarkundu |  |
| 22 | Ankita Chandra           | Ankita Chandra | DN - Kamarkundu |  |
| 23 | Subhrajit Dey            | Rupsha Dey     | Burdwan         |  |
| 24 | <del>Subhrajit Dey</del> | Nivedita Das   | DN/Kamarkundu   | আওতা -> অতিরিক্ত                                 |
| 25 | Purnima Koley            | Sangita Koley  | DN - Kamarkundu |  |
| 26 | Bandana Roy              | Aishwarya Roy  |                 |  |
| 27 | Japan Kumar Ash          | Sreyas Ash     | DN -            |  |
| 28 | Sujata Kayal             | Sujata Kayal   |                 |  |
| 29 | Ashmita Ghosh            | Sanjukta Ghosh |                 |  |
| 30 |                          | Snehashree De  |                 |  |
| 31 | Annapurna Mondal         | Soma Mondal    |                 |  |
| 32 |                          |                |                 |  |

Signature of the Faculty Members

Soma Roy,  
Principal  
Serampore Girls' College  
Serampore, Hooghly

Students Details for Educational Excursion

| Name of Students  | Roll No. | Age | Mobile Number | Emergency contact           |
|---|----------|-----|---------------|-----------------------------|
| <b>students details and tour schedule for the field visit</b> |          |     |               |                             |
| Piyali Chandra  | 20328    | 19  | 9330142805    | 8420505654                  |
| Sujata Kayal  | 20346    | 19  | 8697359423    | 8017016279                  |
| SANJUKTA SHARMA   | 20709    | 20  | 9883698325    | 9433392499                  |
| Manisha santra  | 20323    | 22  | 7044972370    | 9831688446                  |
| Priyanka Dalui  | 20330    | 19+ | 6289221960    | 9038030797                  |
| Priti Tatawa  | 20329    | 20  | 6289583808    | 7439080960                  |
| Dishita De  | 20320    | 21  | 9748684892    | 8617250351                  |
| Soma Mondal   | 20342    | 20  | 7980720058    | 9874403343                  |
| Suparna Adhikary  | 20347    | 21  | 8346998422    | 9474155297                  |
| Arpita Malik  | 20317    | 20  | 9749837504    | +91 6295027381              |
| Rinku Dey   | 20331    | 20  | 8981363921    | 8697916392                  |
| Soumini Dutta   | 20344    | 21  | 8478878343    | 8902226034                  |
| Rupsha Dey  | 20332    | 20+ | 7478126326    | 9679769595                  |
| Saba Parween  | 20333    | 20  | 9330630355    | 6291758898                  |
| Aishwarya Roy   | 20314    | 20  | 7439477496    | 9831368257                  |
| Pallabi Majhi   | 20325    | 21  | 9674577081    | 9674000461                  |
| Soumi Dey   | 20343    | 18+ | 9007592179    | 9831886569                  |
| Barsha Nayak  | 20319    | 19+ | 7044458886    | 8013262998                  |
| Nibedita Das  | 20324    | 20  | 7449755028    | 9831123317                  |
| Sangita Koley   | 20336    | 20  | 9.19749E+11   | 9831870767                  |
| Shreya Ghosh  | 20338    | 20  | 7318745863    | 9434643997                  |
| Snehashree De   | 20341    | 19+ | 7439566956    | 9475748371                  |
| Payel Pal   | 20327    | 21  | 6290810913    | 8335912264/9477989984       |
| Shahin banu   | 20337    | 20  | 8100010616    | 8961765626                  |
| Doniya pramanick  | 20321    | 20  | 9883102732    | 9432590451                  |
| Sreya Ash   | 20345    | 20  | 8274979424    | 9831950544                  |
| Barsha Malik  | 20318    | 20  | 9339061608    | 9339061608 or<br>9163338571 |
| Sneha Tudu  | 20340    | 21  | 9123367081    | 9007927896                  |
| Ankita Chandra  | 20315    | 19+ | 9433898661    | 9432287108                  |
| Sanchaita Das   | 20334    | 18  | 7439636226    | 9831112845                  |
| Lisa Majumder   | 20322    | 21  | 8158813931    | 9332387590                  |

*Soma Roy,*  
 Principal  
 Serampore Girls' College  
 Serampore, Hoopla

images in Mirik and Darjeeling during field visit



मिरिक खण्ड प्राथमिक स्वास्थ्य केंद्र  
मिरिक, दार्जीलिंग

images in Mirik and Darjeeling during field visit





GPS Map Camera



**Mirik, West Bengal, India**

V5PJ+566, Dilmaya Rd, Mirik, West Bengal

734214, India

Lat 26.88541°

Long 88.180406°

17/09/22 10:40 AM GMT +05:30

images in Mirik and Darjeeling during field visit



images in Mirik and Darjeeling during field visit



GPS Map Camera

Mirik, West Bengal, India

Hotel Jagjit Alipurduar Road, V5PQ+J43, Mirik, West Bengal 734214, India

Lat 26.886444°

Long 88.187757°

17/09/22 09:57 AM GMT +05:30

Soma Roy,  
Principal  
Serampore Girls' College  
Serampore, Hoopla

**Project work/field work/ internships**  
**Name of Course: Techniques of Social Research**  
**Code: SEC A1**  
**DEPT: SOCIOLOGY**  
**2022-2023**

# Criteria 1.3.2

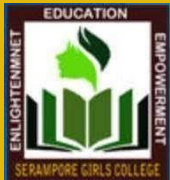

## Serampore Girls College

13, T.C. Goswami Street,  
Serampore, Hooghly – 712201, West Bengal  
Re- Accredited by NAAC : Grade B (2nd Cycle)  
Email: [serampore\\_girls\\_college@yahoo.co.in](mailto:serampore_girls_college@yahoo.co.in)  
Website: [www.seramporegirlscollege.org](http://www.seramporegirlscollege.org)

# Serampore Girls' College

13, T.C. Goswami Street Serampore Hooghly - 712201 West Bengal

## NAAC Criteria 1.3.2



### FIELD VISIT REPORT 2022-2023

**Department: SOCIOLOGY**

**Academic Session: 2022-2023**

**SEMSTER: V (FIVE) GEN**

**Name of Course: Techniques of Social Research**

**Code: SEC A1**

**Location: Serampore Area, Singur Area, Barracpore Area, WEST BENGAL**

**Course Objective:**

Students will learn

- To Fulfil the course requirement of Calcutta University (affiliating university) syllabus
- To teach the students how to conduct a social research
- To grasp sound knowledge on research techniques

**Date:** Aug 2022- Oct 2022

**Duration:** 3 months

**students participated:** 36

**Name of Teachers:**

- Dr Saswati Chanda (Teacher, Dept of Sociology, Serampore Girls' College)
- Dr. Aritra Ghosh (Teacher, Dept of Sociology, Serampore Girls' College)

**Course Outcome:**

- Requirement of Calcutta University (affiliating university) syllabus fulfilled
- students learned how to conduct a social research
- students sound knowledge on research techniques

*Soma Roy,*  
Principal  
Serampore Girls' College  
Serampore, Hooghly

Signature of Principal

# syllabus of the course for field visit

**Confidential**

|    |                   |  |   |   |   |
|----|-------------------|--|---|---|---|
|    | Philosophy        | Honours & General : All courses            | To be determined by UGBOS.  | To be done by College Faculty following the instructions of UGBOS.  | - |
| 11 | Political Science | Honours & General : All courses            | Any one of the following Modes:<br>a) Written: one term paper of 1000 words or two term paper of 500 words/ equivalent book review / comprehension / quotation<br>b) Presentation Mode : Report/Poster/Field work – 15 marks                                | To be done by College Faculty following the instructions of UGBOS.  | - |
| 12 | Sociology         | Honours & General : All courses<br><br>DSE | Written mode – 15 marks (topics by college Faculty) - Term paper/Book review/Excerpt review/Comprehension<br>Presentation mode – Paper or Report / Poster / Field work – 15 marks<br><br>Field work and Dissertation to be decided by the Internal Faculty. | To be done by College Faculty following the instructions of UGBOS.<br><br>Viva Voce by external examiner. | - |
| 13 | Sanskrit          | Honours & General : All courses            | Objective/MCQ - 10 marks out of 15 marks are to be answered in Sanskrit and Devanagari script.<br>5 objective type question of 2 marks each to be answered in Sanskrit (out of seven such questions)  | Internal examiners as per the instructions of UGBOS.  | - |

*Soma Roy.*  
 Principal  
 Serampore Girls' College  
 Serampore, Hoopla

## attendance of students

| 5th semester 2022, SOCG |       |                      |                |                  | Signature             |
|-------------------------|-------|----------------------|----------------|------------------|-----------------------|
| sl                      | Roll  | Name                 | CU Roll        | CU Reg           |                       |
| 1                       | 20354 | ANANYA KARMAKAR      | 202614-12-0100 | 614-1211-0476-20 | Ananya Karomakar      |
| 2                       | 20355 | ANANYA SANTRA        | 202614-12-0225 | 614-1212-0371-20 |                       |
| 3                       | 20356 | ANISHA PAL           | 202614-12-0002 | 614-1211-0340-20 | Anisha Pal            |
| 4                       | 20361 | ANKITA SANTRA        | 202614-12-0316 | 614-1211-0681-20 | Ankita Santra.        |
| 5                       | 20362 | ANTARA GHOSH         | 202614-12-0290 | 614-1214-0499-20 | Antara Ghosh          |
| 6                       | 20363 | ANTARA RAY           | 202614-12-0158 | 614-1211-0559-20 | Antara Ray.           |
| 7                       | 20366 | ARCHA CHAL           | 202614-12-0281 | 614-1214-0425-20 | Archa Chal            |
| 8                       | 20371 | ASIMA KHELO          | 202614-12-0006 | 614-1211-0345-20 | Asima Khelo           |
| 9                       | 20372 | ASLEMA KHATUN        | 202614-12-0306 | 614-1215-0552-20 | Aslema Khatun.        |
| 10                      | 20408 | KHADUJA KHATUN       | 202614-12-0135 | 614-1211-0529-20 | Khadija Khatun        |
| 11                      | 20411 | LILI KOLEY           | 202614-12-0252 | 614-1212-0522-20 |                       |
| 12                      | 20413 | MADHUMITA SHAW       | 202614-12-0297 | 614-1214-0633-20 | Madhumita Shaw        |
| 13                      | 20414 | MADHUPARNA SINGH     | 202614-12-0278 | 614-1213-0470-20 | Madhuparna Singh      |
| 14                      | 20421 | MOUMITA BAIDYA       | 202614-12-0229 | 614-1212-0384-20 | Moumita Baidya        |
| 15                      | 20423 | MOUMITA DAS          | 202614-12-0043 | 614-1211-0396-20 | Moumita Das           |
| 16                      | 20428 | MOUSUMI GHOSH        | 202614-12-0282 | 614-1214-0426-20 | Mousumi Ghosh         |
| 17                      | 20431 | NAMIRA KHATUN        | 202614-12-0315 | 614-1211-0680-20 | Namira Khatun         |
| 18                      | 20435 | NEHA SHA             | 202614-12-0279 | 614-1214-0399-20 | Neha Sha              |
| 19                      | 20444 | PAYEL BHAR           | 202614-12-0165 | 614-1211-0568-20 | Payel Bhar            |
| 20                      | 20448 | PHALGUNI CHAKRABORTY | 202614-12-0160 | 614-1211-0561-20 | Phalguni Chakraborty. |
| 21                      | 20450 | PINKI BERA           | 202614-12-0101 | 614-1211-0477-20 |                       |
| 22                      | 20452 | PIU DEY              | 202614-12-0172 | 614-1211-0579-20 | Piu Dey               |
| 23                      | 20458 | PRIASA DHAR          | 202614-12-0034 | 614-1211-0385-20 |                       |
| 24                      | 20464 | PRITI GANGULY        | 202614-12-0018 | 614-1211-0357-20 | Priti Ganguly.        |
| 25                      | 20466 | PRITI ROY            | 202614-12-0238 | 614-1212-0448-20 | Priti Roy             |
| 26                      | 20467 | PRITI SANTRA         | 202614-12-0014 | 614-1211-0353-20 | Priti Santra          |
| 27                      | 20468 | PRITIKA BARMAN       | 202614-12-0255 | 614-1212-0544-20 | Pritika Barman        |
| 28                      | 20470 | PRIYA BAR            | 202614-12-0177 | 614-1211-0585-20 |                       |
| 29                      | 20477 | PRIYANKA DAS         | 202614-12-0231 | 614-1212-0397-20 | Priyanka Das          |

## Attendance of Students for field visit

|    |       |                     |                |                  |                 |
|----|-------|---------------------|----------------|------------------|-----------------|
| 30 | 20485 | PUNAM SHAW          | 202614-12-0052 | 614-1211-0409-20 | Punam Shaw      |
| 31 | 20495 | RIMPA KOLEY         | 202614-12-0109 | 614-1211-0490-20 |                 |
| 32 | 20499 | RINKU DAS           | 202614-12-0044 | 614-1211-0398-20 |                 |
| 33 | 20505 | RIYA DUTTA          | 202614-12-0001 | 614-1211-0338-20 | Riya Dutta      |
| 34 | 20518 | SABINA YIASMIN      | 202614-12-0157 | 614-1211-0558-20 | Sabina Yiasmin  |
| 35 | 20521 | SAHANAZ PARVIN GAZI | 202614-12-0190 | 614-1211-0601-20 |                 |
| 36 | 20524 | SAIMA TAZEIN        | 202614-12-0162 | 614-1211-0563-20 | Saima Tazein    |
| 37 | 20526 | SAMINA KHATUN       | 202614-12-0143 | 614-1211-0539-20 | Samina Khatun   |
| 38 | 20527 | SAMPREETY BARIK     | 202614-12-0012 | 614-1211-0351-20 | Sampreety Barik |
| 39 | 20544 | SHARMILA SARKAR     | 202614-12-0317 | 614-1211-0683-20 | Sharmila Sarkar |
| 40 | 20545 | SHILA PATRA         | 202614-12-0230 | 614-1212-0386-20 | Shila Patra     |
| 41 | 20550 | SHREYA DAS          | 202614-12-0072 | 614-1211-0434-20 | Shreya Das.     |
| 42 | 20553 | SIYA DHARA          | 202614-12-0029 | 614-1211-0379-20 |                 |
| 43 | 20555 | SOHANI SHAW         | 202614-12-0023 | 614-1211-0364-20 | Sohani Shaw     |
| 44 | 20556 | SOLANKI DE          | 202614-12-0313 | 614-1231-0593-20 |                 |
| 45 | 20558 | SONALI SHAW         | 202614-12-0059 | 614-1211-0417-20 | Sonali Shaw     |
| 46 | 20559 | SONI SINGH          | 202614-12-0113 | 614-1211-0494-20 |                 |
| 47 | 20563 | SRABANI MALIK       | 202614-12-0228 | 614-1212-0378-20 |                 |
| 48 | 20568 | SUDIPA MALIK        | 202614-12-0218 | 614-1212-0343-20 |                 |
| 49 | 20583 | SURJU HEMRAM        | 202614-12-0277 | 614-1213-0457-20 |                 |
| 50 | 20591 | SWATI MAL           | 202614-12-0280 | 614-1214-0423-20 | Swati Mal.      |
| 51 | 20708 | PRIYANKA GHOSH      | 202614-12-0211 | 614-1211-0644-20 |                 |
| 52 | 20715 | JUYENA PARVIN       | 202614-12-0215 | 614-1211-0648-20 |                 |
| 53 | 19658 | SHREYA SIKDAR       | 192614-12-0077 | 614-1212-0726-19 | Shreya Sikdar   |

Soma Roy.  
Principal  
Serampore Girls' College  
Serampore, Hooghly

## Sociology Field visit images



Sociology Field visit images



Sociology Field visit images



Sociology Field visit images



Soma Roy,  
Principal  
Serampore Girls' College  
Serampore, Hooghly

**Project work/field work/ internships**  
**Name of Course: Plant diversity 1**  
**Code: BOTG-CC1/GE1**  
**DEPT: BOTANY**  
**2022-2023**

## **Criteria 1.3.2**



## **Serampore Girls College**

13, T.C. Goswami Street,  
Serampore, Hooghly – 712201, West Bengal  
Re- Accredited by NAAC : Grade B (2nd Cycle)  
Email: [serampore\\_girls\\_college@yahoo.co.in](mailto:serampore_girls_college@yahoo.co.in)  
Website: [www.seramporegirlscollege.org](http://www.seramporegirlscollege.org)



## FIELD WORK REPORT 2022-2023 (BOTANY)

### Report on local excursion

#### Semester-1

- **Name of the course:** Plant diversity 1
- **Date:** 19/12/2022
  
- **Objective:** Local excursion is a compulsory part of B.Sc Botany (General) degree course of semester V under CBCS curriculum. The aim is giving students a proper idea of medicinal plants, their uses and information about maintenance of the garden.
  
- **Code of the course:** BOTG-CC1/GE1
  
- **No. of students attended:** 5
  
- **Location of Visit:** Serampore locality
  
- **Outcome:** Students of semester I took part enthusiastically to fulfil our goal, they gathered knowledge about different plant groups, their habit, habitat and their ecological importance. It was beneficial
  
- **Guided by:** Dr. Madhusree Halder, Department of Botany, Serampore Girls' College.

*Soma Roy.*  
Principal  
Serampore Girls' College  
Serampore, Hooghly

Signature of Principal



### Syllabus of 1<sup>st</sup> semester BOTG-CC1/GE1- P

**PRACTICAL- PLANT DIVERSITY I (PHYCOLOGY, MYCOLOGY, PHYTOPATHOLOGY, BRYOPHYTES AND ANATOMY) (BOT-G-CC-1-1-P)  
(Credits 2)**

- 1. Work out:** Microscopic preparation, drawing and labeling of *Chlamydomonas*, *Chara*, *Ectocarpus*, *Rhizopus* and *Ascobolus*
- 2. Anatomical studies (following double staining method) of:** 2a. Stem- *Cucurbita*, sunflower and maize. 2b. Root- *Colocassia*, gram and orchid. 2c. Leaf- *Nerium*
- 3. Identification with reasons:** 3a. Cryptogamic specimens (macroscopic/microscopic as prescribed in the theoretical syllabus. 3b. Pathological specimens (herbarium sheets) of Late blight of potato, Brown spot of rice and stem rot of jute.
- 4. Laboratory records:** Laboratory note books (regularly signed) and slides (prepared in class) are to be submitted at the time of Practical Examination. Regular attendance in the class must be credited.
- 5. At least one local excursion** to be conducted to give an idea of plant diversity, habitat of algae and fungi

Soma Roy.  
Principal  
Serampore Girls' College  
Serampore, Hooghly

Signature of Principal

# Serampore Girls' College

13, T.C. Goswami Street Serampore Hooghly - 712201 West Bengal

## NAAC Criteria 1.3.2



### NOTICE:

**Serampore Girls' College**  
(Estd.: 1981)  
Accredited by NAAC  
13, T. C. GOSWAMI STREET, SERAMPORE, HOOGHLY, PIN-712 201, WEST BENGAL.  
Ph: (033) 2652 9334 • (033) 26527850 (Principal) • 26623723 (Office) • 2652-0008  
E-mail : science@seramporegirlscollge.org • sgc.scdept@gmail.com

DEPARTMENT OF BIO-SCIENCE

Ref. No. .... Date 14/12/2022

**NOTICE**

Students of semester I, Bio science general are hereby informed that there is a local excursion is organized at serampore locality from Department of Botany Serampore Girls College, Hooghly on 19/12/2022 All students are instructed to attend the excursion. You must carry a note book, pen, camera, College Id card with you.

Handed 14/12/2022

Signature of Teacher (s)

Department of Botany  
Serampore Girl's College  
Serampore, Hooghly

Soma Roy,  
Principal  
Serampore Girls' College  
Serampore, Hooghly

Signature of Principal



# Serampore Girls' College

13, T.C. Goswami Street Serampore Hooghly - 712201 West Bengal

## NAAC Criteria 1.3.2



### Photos of the event



Soma Roy,  
Principal  
Serampore Girls' College  
Serampore, Hooghly

Signature of Principal

Project work/field work/ internships  
Name of Course: Phytochemistry and medicinal Botany  
Code: BOTG-DSE-A-5-1-P  
DEPT: BOTANY  
2022-2023

## Criteria 1.3.2



## Serampore Girls College

13, T.C. Goswami Street,  
Serampore, Hooghly – 712201, West Bengal  
Re- Accredited by NAAC : Grade B (2nd Cycle)  
Email: [serampore\\_girls\\_college@yahoo.co.in](mailto:serampore_girls_college@yahoo.co.in)  
Website: [www.seramporegirlscollege.org](http://www.seramporegirlscollege.org)



## FIELD WORK REPORT 2022-2023 (BOTANY)

### Report on medicinal garden visit

### Semester-V

- **Name of the course:** Phytochemistry and medicinal Botany
- **Date:** 19/12/2022
- **Objective:** Medicinal garden visit is a compulsory part of B.Sc Botany (General) degree course of semester V under CBCS curriculum. The aim is giving students a proper idea of medicinal plants, their uses and information about maintenance of the garden.
- **Code of the course:** BOTG-DSE-A-5-1-P
- **No. of students attended:** 6
- **Location of Visit:** Serampore College
- **Outcome:** Students of semester V took part enthusiastically to fulfil our goal, they experienced different practical facts regarding methods of use of medicinal plants and specifically parts of plants used for different diseases.
- **Guided by:** Dr. Madhusree Halder, Department of Botany, Serampore Girls' College.  
Dr. Suman Datta, Department of Botany, Serampore College.

*Soma Roy.*  
Principal  
Serampore Girls' College  
Serampore, Hooghly

Signature of Principal



### Syllabus of 5<sup>th</sup> semester BOTG-DSE-A-5-1-P

#### **PRACTICAL- PHYTOCHEMISTRY AND MEDICINAL BOTANY (BOT-G-DSE-A-5-1-P) (Credit 2)**

1. Preparations of solution and buffers
2. Acquaintance with laboratory instruments- Autoclave, Incubator, Clinical centrifuge, Analytical balance, pH meter, Colorimeter, Water bath, Distillation plant, Laminar air flow.
3. Qualitative test for proteins and carbohydrates, reducing and non reducing sugar (glucose, fructose and sucrose)
4. Tests (chemical) for tannin and alkaloid
5. Identification of medicinal plants (list to be provided)
6. Field study (local) and listing of medicinal plants. Records to be substantiated with photographs and description.

Soma Roy,  
Principal  
Serampore Girls' College  
Serampore, Hooghly

Signature of Principal

# Serampore Girls' College

13, T.C. Goswami Street Serampore Hooghly - 712201 West Bengal

## NAAC Criteria 1.3.2



Ph : (033) 26623723 (Office)

### Serampore Girls' College

(Estd.: 1981)  
Re-Accredited by NAAC : Grade B (2nd Cycle)  
13, T. C. GOSWAMI STREET, SERAMPORE, HOOGHLY, PIN-712 201, WEST BENGAL.  
E-mail : serampore\_girls\_college@yahoo.co.in  
Website : www.seramporegirlscollege.org

Ref. No. \_\_\_\_\_ Date 13/12/22

To  
The Principal,  
Serampore College,  
8, William Carey Sarani, Maniktala,  
Serampore,  
West Bengal 712201

**Subject : Seeking permission to visit Medicinal Garden of your college premises**

Respected Sir,

In CBCS, 5<sup>th</sup> semester Botany curriculum there is a provision of visit to a medicinal garden. I would like to request you to grant our B.Sc general students the permission to visit the medicinal garden at your college premises.

Thanking you,

*Soma Roy*  
Principal  
Serampore Girls' College  
Serampore, Hooghly

*Soma Roy*  
13/12/22

### Serampore College

College/Carey Cemetery Visitation Form

To,  
The Principal,  
Serampore College,  
Serampore, Hooghly.

Date of Request: 13/12/22

1. Requester's Name (attached name's list (Father only): (i) Dr. Madhusree Halder  
(ii) \_\_\_\_\_ (iii) \_\_\_\_\_  
(iv) \_\_\_\_\_ (v) \_\_\_\_\_  
(vi) \_\_\_\_\_ (vii) \_\_\_\_\_

2. Mobile No.: 78411276910

3. Email id: madhusree@seramporegirlscollege.org

4. Any Govt. id No. (preferably Aadhar no.): 52995616 9159

5. Date of Visit: 19/12/2022 Duration of the Visit: 1 hr

6. Place(s) of Visit: (i) College Campus  (ii) Carey Museum  (iii) Carey Cemetery  (iv) Library  (v) Other (please mention the name): Medicinal Garden

7. Purpose of the Visit: To show the students group... method for managing medicinal plants and to provide information on plants that are useful for disease. It is also mentioned in CBSE (C) syllabus.

8. Contact/known Person in College (if any): Dr. Kingshuk Das (HOD, Dept of Botany) Dr. Suman Datta.

Madhusree Halder  
Visitor's Signature 19/12/22

Permitted  Regretted

Dr. Vansanglura  
Principal & CEO

C.C.:  
1. Gate Security    
2. Attendant, CLRC    
3. Guard, Carey Cemetery

Letter of Principal of Serampore Girls College to the Principal of Serampore College for field work visit

Serampore College visitation form for the field work

*Soma Roy*  
Principal  
Serampore Girls' College  
Serampore, Hooghly

Signature of Principal

# Serampore Girls' College

13, T.C. Goswami Street Serampore Hooghly - 712201 West Bengal

## NAAC Criteria 1.3.2



Serampore Girls' College  
(Estd. : 1981)  
Accredited by NAAC  
13, T. C. GOSWAMI STREET, SERAMPORE, HOOGHLY, PIN - 712 201, WEST BENGAL.  
Ph: (033) 2652-9334 • (033) 26527850 (Principal) • 26623723 (Office) • 2652-0008  
E-mail : science@seramporegirlscollege.org • sgc.scdept@gmail.com

DEPARTMENT OF BIO-SCIENCE

Ref. No. .... Date..... 14/12/22

**NOTICE**

Students of semester V, Bio science general are hereby informed that there is a medicinal garden visit organized from Department of Botany Serampore Girls College, at Serampore College campus, Hooghly on 19/12/2022 All students are instructed to attend the excursion. You must carry a note book, pen, camera, College Id card with you.

M. Das 14/12/22

Signature of Teacher (s)

Department of Botany  
Serampore Girls' College  
Serampore, Hooghly

### NOTICE BY HOD DEPT OF BOTANY

Soma Roy,  
Principal  
Serampore Girls' College  
Serampore, Hooghly

Signature of Principal

# Serampore Girls' College

13, T.C. Goswami Street Serampore Hooghly - 712201 West Bengal

## NAAC Criteria 1.3.2



### Student's attendance sheet:

**SERAMPORE GIRLS' COLLEGE**  
DEPARTMENT OF BOTANY

Student attendance sheet

Program: *Visit to medicinal garden* Date: *19/12/2022*

| Sl. No. | Roll Number | Semester | Signature of the student |
|---------|-------------|----------|--------------------------|
| 1.      | 20688       |          | Anannya Das              |
| 2.      | 20696       |          | Mahima Chakraborty       |
| 3.      | 20697       |          | Prati Maji               |
| 4.      | 20694       |          | Shrestha Guha            |
| 5.      | 20692       |          | June Ghosh               |
| 6.      | 20699       |          | Jayashree Debnath        |
|         |             |          |                          |
|         |             |          |                          |
|         |             |          |                          |
|         |             |          |                          |
|         |             |          |                          |
|         |             |          |                          |
|         |             |          |                          |
|         |             |          |                          |
|         |             |          |                          |
|         |             |          |                          |
|         |             |          |                          |

*Ananya*  
*19/12/2022*  
Department of Botany  
Serampore Girls' College  
Serampore, Hooghly

Soma Roy,  
Principal  
Serampore Girls' College  
Serampore, Hooghly

Signature of Principal

# Serampore Girls' College

13, T.C. Goswami Street Serampore Hooghly - 712201 West Bengal

## NAAC Criteria 1.3.2



### Photos of the event



Soma Roy,  
Principal  
Serampore Girls' College  
Serampore, Hooghly

Signature of Principal

Project work/field work/ internships  
Name of Course: ARDUINO (PROJECT TYPE)  
Code: SEC B1  
DEPT: Physics  
2022-2023

# Criteria 1.3.2



## Serampore Girls College

13, T.C. Goswami Street,  
Serampore, Hooghly – 712201, West Bengal  
Re- Accredited by NAAC : Grade B (2nd Cycle)  
Email: [serampore\\_girls\\_college@yahoo.co.in](mailto:serampore_girls_college@yahoo.co.in)  
Website: [www.seramporegirlscollege.org](http://www.seramporegirlscollege.org)

# Serampore Girls' College

13, T.C. Goswami Street Serampore Hooghly - 712201 West Bengal

## NAAC Criteria 1.3.1



## PROJECT WORK REPORT 2022-2023

### REPORT ON PROJECT WORK OF Arduino SEC B -1 (PHYSICS)

Academic Session: 2022-2023

SEMSTER: IV ( GEN)

Name of Course: ARDUINO (PROJECT TYPE)

Code: SEC B1

**Location:** Serampore Girls' College, WEST BENGAL

**Course Objective:**

Students will learn

- 1. LED Blinking and fading. 2. Measurement of voltages (Below 5 V and above). 3. Interfacing 7 Segment display. 4. Construction of thermometer using LM35 or Others

**Date of report submission:** 25/06/2023 to 27/06/2023

**Duration:** 6 months ( 1 semester)

**students enrolled:** 4

**Student submitted:** 4

**Guided by:**

Dr. Sandip Majumdar ( Department of Physics, Serampore Girls' College)

**Course Outcome:**

- Students were able to learn basic projects using Arduino Uno kit.

*Sandip Majumdar*  
Head of the Department  
Department of Physics

*Soma Roy.*  
Principal  
Serampore Girls' College  
Serampore, Hooghly

## SEC B -1 (Technical Skill)

### 4.2 Arduino (Project type)

#### 4.2.1 Arduino

|                      |          |
|----------------------|----------|
| Paper PHS-A-SEC-B-TH | Credit 1 |
|----------------------|----------|

##### 1. Introduction to Arduino

2 Lectures

Brief history of the Arduino; open-source electronics prototyping.

##### 2. Basic ideas

3 Lectures

Basic ideas of Arduino, Familiarize the Arduino board, Setting up the arduino board. Installation of IDE in PC/ laptop for Arduino programming(Sketch)

##### 3. Arduino Programming:

10 Lectures

###### (a) Program structure:

data types, variables and constants, operators, control statements, loops, functions, string.

###### (b) Interfacing:

serial communication, digital and analog input/output, getting input from sensors(e.g. temperature sensor, ultrasonic sensor etc)

##### Books and references

1. Arduino Cookbook, Michael Margolis, O'Reilly Media (2011)
2. Getting Started with Arduino, Massimo Banzi, O'Reilly Media(2009)
3. Arduino as a tool for physics experiments, Giovanni Organtini 2018 J. Phys.: Conf. Ser. 1076 012026
4. <https://www.arduino.cc/en/Guide/HomePage>
5. Physics Today 66, 11, 8 (2013); <https://doi.org/10.1063/PT.3.2160>
6. The Physics Teacher 52, 157 (2014); <https://doi.org/10.1119/1.4865518>

#### 4.2.2 Practical Projects

|                      |          |
|----------------------|----------|
| Paper PHS-A-SEC-B-PR | Credit 1 |
|----------------------|----------|

1. LED Blinking and fading.
2. Measurement of voltages (Below 5 V and above).
3. Interfacing 7 Segment display.
4. Construction of thermometer using LM35 or Others.

5. Construct the experimental set up for studying simple pendulum and hence determine the acceleration's due to gravity.

6. Construct data logger for studying charging and discharging of RC circuit.

**NOTE: Software required: Arduino Integrated Development Environment, Hardware required: Arduino Uno**

## SEC B -2 (Knowledge Skill)

### 4.3 Electrical Circuits and Network skills (Theory)

PHS-A SEC-B -TH

Credit 2

#### 1. DC generator :

10 Lectures

(a) EMF generated in the armature for simplex lap and wave winding, concept of pole, Methods of Excitation, Armature reaction, Dc motor : Torque equation of D.C motor, speed & torque Operating Characteristics of separately excited, Shunt, Series & Compound motors with emphasis on application areas.

(b) Three phase generator, concept of stator and rotor, star and delta connections – their current voltage relationships (both line and phase current & voltage).

#### 2. Transformer :

5 Lectures

Types of transformer, basic emf equation, no load current, leakage inductance, Magnetising current and equivalent circuit of single phase transformer on no-load and on load, idea of star/star, star/delta, delta/star, and zig-zag connection of 3 phase transformer, 3 phase to 2 phase transformation, Scott T connection.

#### 3. AC motor

6 Lectures

(a) Single phase AC motor – double field revolving theory, slip-speed characteristics,

(b) Construction of 3 phase induction motor and its action using rotating field theory, equivalent circuit of induction motor, Speed control by V/f control of induction motor (block diagram only).

#### 4. Measurements and faults

9 Lectures

(a) Measurement of three phase power by two and three wattmeter method, theory of induction type wattmeter and its use as energy meter in domestic house. Megger.

(b) Unsymmetrical faults in distribution system, Common switchgear equipments like relay, circuit breakers and fuses, Simple oil circuit breaker and SF6 circuit breaker, Construction of protective relay in distribution bus-bar system, Block diagram of a utility distribution sub-station.

#### Reference Books

1. Text book on Electrical Technology (vol 1 & 2), Thereja and Thereja
2. Power System, V. K. Meheta
3. Electrical Machines, S. K. Bhattacharya

# Serampore Girls' College

13, T.C. Goswami Street Serampore Hooghly - 712201 West Bengal

## NAAC Criteria 1.3.1



### NOTICE FOR PROJECT ASSIGNMENTS

#### NOTICE FOR PROJECT PRACTICAL ASSIGNMENT

SEM IV Paper: Arduino

Code: SEC-B1

Subject : Physics

| SI | Name         | Roll  | Name of the Project                              |
|----|--------------|-------|--|
| 1  | Asiya Parvin | 21344 | LED Blinking and fading.                         |
| 2  | Moshahida    | 21351 | Measurement of voltages (Below 5 V and above).   |
| 3  | Shana Shahid | 21366 | Interfacing 7 Segment display                    |
| 4  | Nishu Bhagat | 21355 | Construction of thermometer using LM35 or Others |

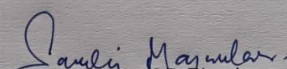
  
Signature of HOD Physics

College/Centre : SERAMPORE GIRLS COLLEGE (614)

Subject : PHSG

Course : SEC-B1

Subject Category : GENERAL

Assessment Type : Practical

Course Name : ARDRUINO

Foil No. : 1886

| Srl No. | Roll Numbers   | Registration Numbers | Signature of Candidates | [FM 60]        |            |
|---------|----------------|----------------------|-------------------------|----------------|------------|
|         |                |                      |                         | Marks Obtained |            |
|         |                |                      |                         | Examiner       | Scrutineer |
| 1       | 213614-12-0004 | 614-1211-0726-21     | Nishu Bhagat            |                |            |
| 2       | 213614-12-0015 | 614-1211-0739-21     | Moshakida Tabassum      |                |            |
| 3       | 213614-12-0036 | 614-1215-0747-21     | Asiya Farvin            |                |            |
| 4       | 213614-12-0037 | 614-1215-0749-21     | Shana Sahid             |                |            |

Signature of Internal Examiner(s)

Signature of Scrutineer(s)

Signature of Principal/TIC/OIC/HE with date &amp; seal

# PROJECT REPORT ON

## ARDUINO

Subject: Physics  
Paper: SEC  
Paper code: B1

Presented by:

NISHU BHAGAT  
CU Roll: 213614-12-0004  
Registration no:- 614-1211-0726-21  
College roll no;- 21355  
Semester: 4<sup>TH</sup>

Serampore Girls College  
13, T.C. Goswami Street Serampore Hooghly - 712201 West Bengal





# PROJECT REPORT ON

LED Blinking and fading

Subject : Physics

Paper : Arduino

Paper : **PHSG**

Presented by,

**ASIYA PARVIN**

CU Roll No. : 213614-12-0036

Registration No. : 614-1215-0747-21

College Roll No. : 2130144

Semester : 4<sup>th</sup>

Serampore Girls College

13, T.C. Gosawami Street Serampore Hooghly- 712201, West Bengal



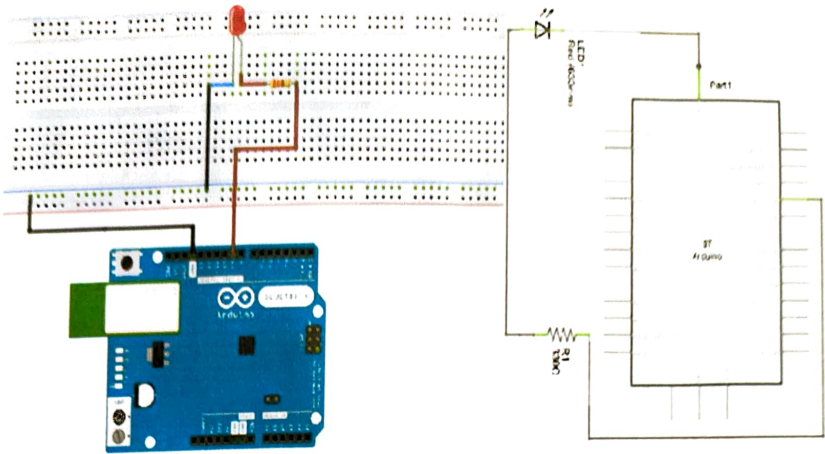

NOTE - To find out the polarity of an LED, look at it closely. The shorter of the two legs, towards the flat edge of the bulb indicates the negative terminal.

Components like resistors need to have their terminals bent into 90° angles in order to fit the breadboard sockets properly. We can also cut the terminals shorter.

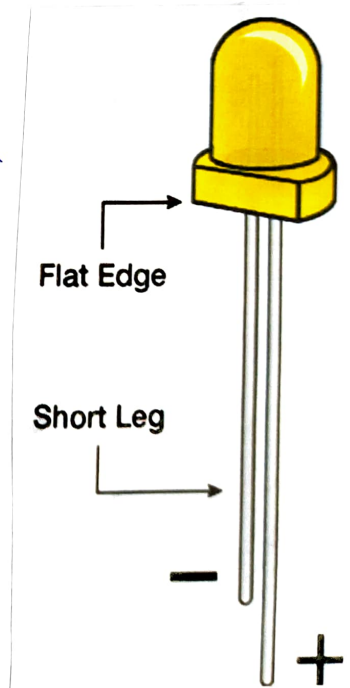
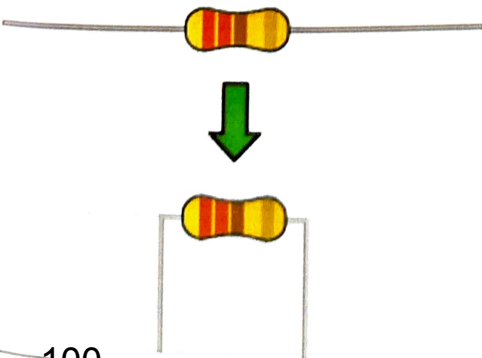

**Project work/field work/ internships**  
**Name of Course: Folk culture and Folk Literature**  
**Code: BNGA-DSEB-6-4**  
**DEPT: Bengali**  
**2022-2023**

## Criteria 1.3.2

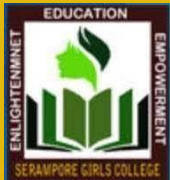

## Serampore Girls College

13, T.C. Goswami Street,  
Serampore, Hooghly – 712201, West Bengal  
Re- Accredited by NAAC : Grade B (2nd Cycle)  
Email: [serampore\\_girls\\_college@yahoo.co.in](mailto:serampore_girls_college@yahoo.co.in)  
Website: [www.seramporegirlscollege.org](http://www.seramporegirlscollege.org)

# Serampore Girls' College

13, T.C. Goswami Street Serampore Hooghly - 712201 West Bengal

## NAAC Criteria 1.3.2



## FIELD WORK REPORT 2022-2023 (BENGALI)

Department: BENGALI

Academic Session: 2022-2023

SEMSTER: VI (HONS)

**Name of Course: Folk culture and Folk Literature (লোকসংস্কৃতি ও লোকসাহিত্য)**

**Code: BNGA-DSEB-6-4**

**Location: Shantiniketan, Bolpur Srijani Silpa Gram**

**Course Objective: Practical knowledge of Folk Literature and Folk Songs.**

### **How to collect and preserve Folk Culture**

**Date: 12.04 2023**

**Duration: 8 hours**

**No of Students participated: 18**

**Name of Teachers: 4**

- i. Dr. Sampa Sarkar (Associate Professor, Dept of Bengali, Serampore Girls' College)
- ii. Dr. Snigdha Chattopadhyay (Associate Professor, Dept of Bengali, Serampore Girls' College)
- iii. Smt. Nandita Das Chowdhuri (SACT-2, Dept of Bengali, Serampore Girls' College)
- iv. Dr. Paromita Tikadar (Guest Lecturer, Dept of Bengali, Serampore Girls' College)

### **Course Outcome:**

- Requirement of Calcutta University (affiliating university) syllabus fulfilled.
- Students learned what is Folk culture and Folk Songs.
- How to collect and preserve any Folk Documents.
- Practical knowledge about any Folk culture.

*Soma Roy,*  
Principal  
Serampore Girls' College  
Serampore, Hooghly

Signature of Principal

# Serampore Girls' College

13, T.C. Goswami Street Serampore Hooghly - 712201 West Bengal

## NAAC Criteria 1.3.2



### NOTICE FOR THE FIELD VISIT

Ph. : (033) 26623723 (Office)  
(033) 26527850 (Principal)

**Serampore Girls' College**  
(Estd.: 1981)  
Re-Accredited by NAAC : Grade B (2nd Cycle)  
13, T. C. GOSWAMI STREET, SERAMPORE, HOOGHLY. PIN-712 201, WEST BENGAL.  
E-mail : serampore\_girls\_college@yahoo.co.in  
Website : www.seramporegirlscollege.org

Ref. No. ....

Date 01.04.2023

**NOTICE**

This is to notified that an Educational tour arranged by Bengali Department to visit the Santiniketan, Bolpur Srijani Silpa Gram on 12.04.2023.

Please contact with HOD .

*P*  
Head of the Department  
Department of Bengali  
Serampore Girls' College

*Soma Roy*  
Principal  
Serampore Girls' College  
Serampore, Hooghly

Signature of Principal

# Serampore Girls' College

13, T.C. Goswami Street Serampore Hooghly - 712201 West Bengal

## NAAC Criteria 1.3.2



### SYLLABUS OF THE COURSE

**BNG-A-DSE-B-6-4-TH-TU**  
লোকসংস্কৃতি ও লোকসাহিত্য

কল্পনা : বাঙালি এবং তার সংস্কৃতিকে জানতে গেলে আমাদের লোকসংস্কৃতি ও লোকসাহিত্যের পাঠ নেওয়া খুবই জরুরি। বাংলার সমৃদ্ধ লোক-ঐতিহ্যের থেকে নির্বাচিত কয়েকটি প্রসঙ্গই এখানে পড়ুয়াদের চর্চার জন্য রাখা হচ্ছে।

মডিউল-১

|   | Class Hour |    |         |
|---|------------|----|---------|
|   | Th         | Tu | IA Exam |
| লোকসংস্কৃতি ও লোকসাহিত্যের সাধারণ পরিচয়                        | ২৫         | ৬  | ১       |
| টাইপ ও মোটিফ ইনডেস (বৈশিষ্ট্য ও প্রয়োগ শিক্ষার প্রাথমিক পাঠ)   |            |    |         |
| বাংলার ব্রত ও পার্বন (বিশেষ পাঠ : পূর্ণিাপূর্ন, মাঘমঙল, সৌজুতি) |            |    |         |

মডিউল-২

|  |    |   |   |
|--|----|---|---|
| লোকছড়া                                    | ২৫ | ৬ | ১ |
| লোকনৃত্য (বিশেষ পাঠ : ছৌ, রায়বেশ, গড়ীরা) |    |   |   |
| ধাঁধা                                      |    |   |   |

মডিউল-২

|   |    |   |   |
|---|----|---|---|
| বাংলা প্রবাদ                                      | ২৫ | ৬ | ১ |
| লোকগান (বিশেষ পাঠ : বাউল, ভাটিয়ালী, ভাওয়ালিয়া) |    |   |   |
| লোককথা  |    |   |   |

সহায়ক গ্রন্থ (নির্বাচিত) :

- বাংলার ব্রত—অনীনন্দনাথ ঠাকুর
- বাংলার লোক সাহিত্য—আশুতোষ ভট্টাচার্য
- লোকসংস্কৃতির সীমানা ও স্বরূপ—পদ্ম সেনগুপ্ত
- লোকসংস্কৃতির পরিচিতি ও পঠন-পাঠন—মহাশয় ইসলাম
- বাংলার ব্রত—সুশীলকুমার সেন
- বাংলার ধাঁধার কুনিষ্ঠা—নির্মলেন্দু বৈদিক
- বাংলার ছড়ার কুনিষ্ঠা—নির্মলেন্দু বৈদিক
- বাংলার লোককথার টাইপ ও মোটিফ ইনডেস—বিদ্যাজ্যোতি মজুমদার
- লোক সংস্কৃতি পাঠের কুনিষ্ঠা—তুষার চট্টোপাধ্যায়
- বঙ্গীয় লোকসংস্কৃতিকোষ—বরুণ চক্রবর্তী
- বাংলার লোকসঙ্গীত : ভাটিয়ালি গান—ওয়ালিক আহমেদ
- বাউল মন্দির কথা—সুধীর চক্রবর্তী

Soma Roy,  
Principal  
Serampore Girls' College  
Serampore, Hooghly

Signature of Principal

# Serampore Girls' College

13, T.C. Goswami Street Serampore Hooghly - 712201 West Bengal

## NAAC Criteria 1.3.2



### ATTENDANCE FOR THE FIELD VISIT

**Serampore Girls' College**  
13, T.C. Goswami Street, Serampore, Hooghly - 712201, West Bengal, India  
DEPARTMENT: BENGALI  
STUDY TOUR  
20...<sup>22</sup>... - 20...<sup>23</sup>... Date - 12-04, 2023.

|     |                         |     |                  |
|-----|-------------------------|-----|------------------|
| 1.  | Riya Santra (20034)     | 13. | Sona Koley       |
| 2.  | Diparnita Deb (20048)   | 14. | Rachana Majumdar |
| 3.  | Nikita Purkait (20020)  | 15. | Snradha Dutta    |
| 4.  | Soumi Adak (20046)      | 16. | Ishika Nandy,    |
| 5.  | Sukriti Kundu (20049)   | 17. | Mammi Santra     |
| 6.  | Hritika Malakar (20012) | 18. | Fatema Khataun   |
| 7.  | Arpita Mondal (20044)   |     |                  |
| 8.  | Toishna Das (20056)     |     |                  |
| 9.  | Arpita Mondal (20007)   |     |                  |
| 10. | Tiyasha Dholey. (20054) |     |                  |
| 11. | Iqia Santra (20021)     |     |                  |
| 12. | Rama Das. (20031)       |     |                  |

Soma Roy,  
Principal  
Serampore Girls' College  
Serampore, Hooghly

# Serampore Girls' College

13, T.C. Goswami Street Serampore Hooghly - 712201 West Bengal

## NAAC Criteria 1.3.2



### IMAGES OF THE FIELD VISIT BOLPUR SANTINIKETAN



Soma Roy,  
Principal  
Serampore Girls' College  
Serampore, Hooghly

Signature of Principal

# Serampore Girls' College

13, T.C. Goswami Street Serampore Hooghly - 712201 West Bengal

## NAAC Criteria 1.3.2



### IMAGES OF THE FIELD VISIT BOLPUR SANTINIKETAN



*Soma Roy.*  
Principal  
Serampore Girls' College  
Serampore, Hooghly

Signature of Principal

# Serampore Girls' College

13, T.C. Goswami Street Serampore Hooghly - 712201 West Bengal

## NAAC Criteria 1.3.2



### List of students OF THE FIELD VISIT

## Serampore Girls College

13, T.C. Goswami Street, Serampore, Hooghly- 712201, West Bengal,  
India

DEPARTMENT: BENGALI

STUDY TOUR

2022- 2023

| SL. No | Student Name     | TEACHERS NAME              |
|--------|------------------|----------------------------|
| 1      | RIYA SANTRA      | Dr. SAMPA SARKAR           |
| 2      | DIPANNITA DAS    | Dr. SNIGDHA CHATTOPADHYAY  |
| 3      | NIKITA PURKAIT   | Smt. NANDITA DAS CHOWDHURI |
| 4      | SOUMI ADAK       | Dr. PAROMITA TIKADAR       |
| 5      | SUKRITI KUNDU    |                            |
| 6      | HRITIKA MALAKAR  |                            |
| 7      | ARPITA MANDAL    |                            |
| 8      | TRISHA DAS       |                            |
| 9      | ARPITA MONDAL    |                            |
| 10     | TIYASHA DHOLEY   |                            |
| 11     | PAPIYA SANTRA    |                            |
| 12     | RAMA DAS         |                            |
| 13     | DONA KOLEY       |                            |
| 14     | RACHANA MAJUMDAR |                            |
| 15     | SHRADDHA DUTTA   |                            |
| 16     | ISHITA NANDY     |                            |
| 17     | MAMPI SANTRA     |                            |
| 18     | FATEMA KHATUN    |                            |

*Soma Roy.*  
Principal  
Serampore Girls' College  
Serampore, Hooghly

Signature of Principal



### SAMPLE PROJECT REPORT OF THE FIELD VISIT

শিক্ষা অক্ষর (জ্ঞানিনিকেতন)

নিজস্ব উপবাদনা, সৌমী আদক, রচনা দাস, তপিতা অলুপে, তিপ্রাঙ্গা বিলে ও পালিয়া সঁতরা; জীরামপুর ডালস কলেজ; বাঙ্গা বিহাঙ্গ, ২২ জুন, ২০২৩ :-

২২ এপ্রিল, ২০২৩ বুধবার জীরামপুর ডালস কলেজের সর্ভ অতিথাদের দ্বারা বৃন্দ ও অধ্যাপিকার্যন- শিক্ষা অক্ষরের জ্ঞান জ্ঞানিনিকেতনের উদ্দেশ্যে রতনা হই। অকাল ২০:৪০ মিনিটে আমরা বাঙ্গুর (জ্ঞানিনিকেতন) স্থানে সঁদাই। এরপর সঁদা করে বিশ্বভারতী ও আমলাজের দর্শনীয় জ্ঞান প্রকাশের উদ্দেশ্যে রতনা হই।

আমরা প্রথম 'বাঙ্গাদেজা খেত' সঁদাই। এটি উদ্ভবিত হয় ২৫ মে, ২০২৮-আলে। তারতের শ্রীমতস্বামী নরেন্দ্র জোদী, বাঙ্গাদেজার শ্রীমতস্বামী জোদী গুণিতা দেবী পঙ্কজবণের মুখ্যমন্ত্রী-সভাপতিবাসের উদ্দেশ্যে হই দেজা (বোরত, বাঙ্গাদেজা)-এর জিন্দকলা, রোমা, উদ্ভূতি, ইতিহাস ইত্যাদি বিষয়ে জায়েমতা ও অর্থাভারের লগ্নে এটি প্রতীকিত হয়।

এরপর জ্ঞানিনিকেতন জেলার সর্ভ, বলাকা, জামজাছ, Central library, কলাস্বত, অপরীতস্বত, জ্ঞানিনিকেতন খেত, বাঙ্গাদের জ্ঞান পাঠখেত (জানন্দস্বত), দ্বীন্দ্রস্বত, জুবুজুল, সর্ভসর্ভজাম, জেজু জেতের বাড়ি, জ্ঞানিনিকেতন জামজা, বিশ্বভারতী জ্ঞানপিঠাল, কাচ সর্ভদ্বি বা উপাসনাছ, জাতিসভালা, অর্জনীজিন্দজাম, তিনপাশাছ, জোনাছুতির হর্ভ, ৩৪ সর্ভ উঁচু ব্রহ্ম ছুতি ইত্যাদি দর্শনীয় জ্ঞান আমরা ধর্মন করেছি।

'জামজাছ', এখানে বঙ্গ কবিত্তর 'জামজাছ এক পায়ে সঁদিয়ে' কবিতাটি সিধেহেন, প্রায় তিনজো বছরের পুরোলা সর্ভজাছ। মে খ্যান 'তিনপাশাছ' নামে পরিচিত। এখানে দেবেন্দ্রনাথ চাঁকুর ক্যান করতেন। 'জাতিসভালা'- দেবেন্দ্রনাথ চাঁকুর রামপুরের জিন্দারের বাড়িতে নিছন্বর্ণ- রচনা করতে মাওমার অঙ্গম এই জাতিসভালায় কিছুসর্ভ- বিজ্ঞান নেন। এখানে তিনি প্রাণের জামজা, জানের জানন্দ ও জামজার জ্ঞানি লেয়েহিয়েন।

'অর্জনীজিন্দজাম'- এখানকার এক বিশেষ দর্শনীয় জ্ঞান। ক্যানসর্ভ ব্রহ্ম ছুতি, দ্বীন্দ্রনাথ অর্জনীদেব জুতি, গুজুরে জামজা জুল, হিন্দাচের জামজা, কুটিব, গুজুরে নাচের কিছু জিন্দ, বর্ভেল, নানা ছুতি ও জামজা, পালকি, বর্ভিত্ত দ্বি ইত্যাদি দর্শনীয় বস্তুসর্ভি এখানকার পরিবেশকে অতি জনোরম করে ছেলেছ। এছাড়া এখানে কিছু জুতিজিন্দের দোকানও ছিল।

জোনাছুতির হর্ভের সর্ভসর্ভ প্রু ব্রহ্মব। ব্রহ্মজিন্দের কারুকার্য এই অর্জনী জিন্দা- ত। ছুতি, শ্রায়, জাতি, জামা, ছুতিদার, বেতের তেরি জিন্দা, সঁজা ও কস্টুর তেরি জিন্দা, কর্ভের নানা দ্রব্য ও তার ওপর কারুকার্য দেখে আমরা জুজ। এখান জামে কিছু সর্ভসর্ভ কিতৈছি।

ওবে আমরা জুতিত অব জামজাম প্রবেশ করতে না পারার জ্ঞান। জুবুত এই জুজর জিন্দাসর্ভক অঙ্গের আমরা প্রু জানন্দিত হয়েছি। সেই জামে জনের কিছু জিন্দেছি, জ্ঞান অর্জন করেছি; মা অর্জনিতের পক্ষদর্শনীয় বর্ভে।



### SAMPLE PROJECT REPORT OF THE FIELD VISIT

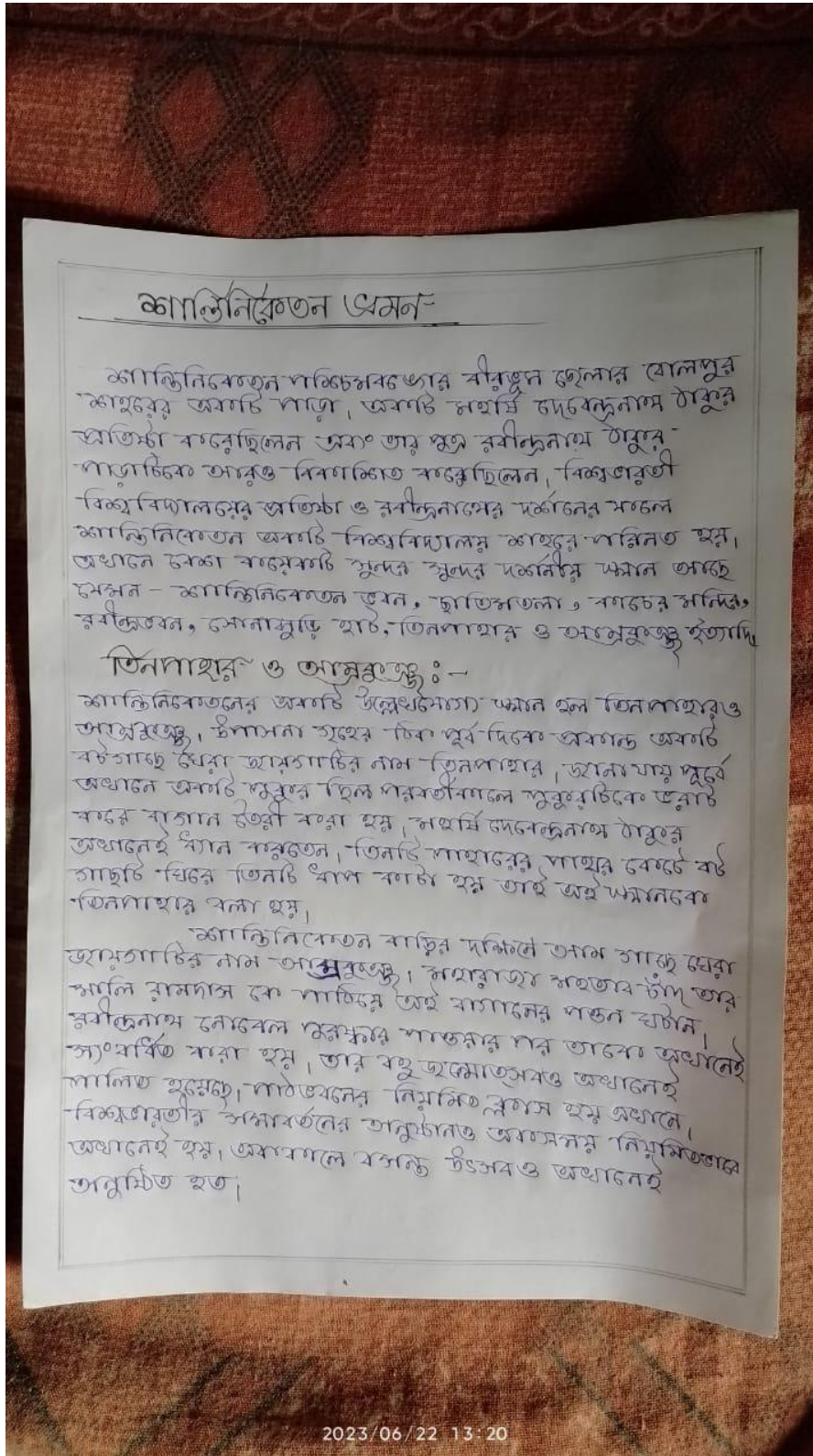

### জ্ঞানিনিবেশন প্রমর্ন

জ্ঞানিনিবেশন পাশ্চিমবঙ্গের বীরভূম জেলার বোলপুর  
"শ্রীমতী দেবেন্দ্রনাথ ঠাকুর" স্কুলে, অর্থাৎ  
শ্রীমতী দেবেন্দ্রনাথ ঠাকুর স্কুলে  
পাঠ্যক্রম অধ্যয়ন বিষয়ে পরিদর্শন করা হয়েছে।  
বিদ্যালয়ের প্রধান শিক্ষক ও সিনিয়র শিক্ষকদের  
জ্ঞানিনিবেশন অর্থাৎ বিদ্যালয়ের জীবন-পন্থা  
অর্থাৎ চরিত্র বিষয়ে সুন্দর সুন্দর আলোচনা করা  
হল - জ্ঞানিনিবেশন ভবন, ছাত্রভবন, বগিচা মন্দির  
স্বীকৃতি, সোনারুড়ি খাঁ, তিনপাথর ও অশ্রুজল ইত্যাদি

### তিনপাথর ও অশ্রুজল :-

জ্ঞানিনিবেশনের অর্থাৎ উল্লেখযোগ্য আলোচনা হল তিনপাথর ও  
অশ্রুজল, উল্লেখযোগ্য অর্থাৎ তিনপাথর অর্থাৎ  
বর্তমানে যেখানে অশ্রুজলের নাম তিনপাথর, অর্থাৎ  
অর্থাৎ অর্থাৎ অর্থাৎ অর্থাৎ অর্থাৎ অর্থাৎ  
অর্থাৎ অর্থাৎ অর্থাৎ অর্থাৎ অর্থাৎ অর্থাৎ  
অর্থাৎ অর্থাৎ অর্থাৎ অর্থাৎ অর্থাৎ অর্থাৎ  
অর্থাৎ অর্থাৎ অর্থাৎ অর্থাৎ অর্থাৎ অর্থাৎ  
অর্থাৎ অর্থাৎ অর্থাৎ অর্থাৎ অর্থাৎ অর্থাৎ

জ্ঞানিনিবেশন বাস্তব দর্শনে অর্থাৎ অর্থাৎ  
অর্থাৎ অর্থাৎ অর্থাৎ অর্থাৎ অর্থাৎ অর্থাৎ  
অর্থাৎ অর্থাৎ অর্থাৎ অর্থাৎ অর্থাৎ অর্থাৎ  
অর্থাৎ অর্থাৎ অর্থাৎ অর্থাৎ অর্থাৎ অর্থাৎ  
অর্থাৎ অর্থাৎ অর্থাৎ অর্থাৎ অর্থাৎ অর্থাৎ  
অর্থাৎ অর্থাৎ অর্থাৎ অর্থাৎ অর্থাৎ অর্থাৎ  
অর্থাৎ অর্থাৎ অর্থাৎ অর্থাৎ অর্থাৎ অর্থাৎ

2023/06/22 13:20

Soma Roy,  
Principal  
Serampore Girls' College  
Serampore, Hooghly

Signature of Principal



### SAMPLE PROJECT REPORT OF THE FIELD VISIT

শিক্ষামন্ডলের ভ্রমণের প্রতিবেদন

স্থান- স্যান্টিনিকেতন (বোনপুর) , তারিখ- ২২ ই এপ্রিল

□ স্মারিকপুর-গান্ধী কলেজ থেকে একটি-শিক্ষামন্ডলের ভ্রমণের আয়োজন করা হয়েছিল, এটি বাবুনা দ্বারক বিজয়া (২০২২-২৩) এর শিক্ষার্থী-ও শিক্ষিকা গণ এর আয়োজনে,

□ স্যান্টিনিকেতন ভবন :- এটিই অশ্রমেব অবশ্যে পুরণে বাড়ি, মহর্ষি দেবেন্দ্রনাথ ঠাকুর-১৮৬৪ সালে এই বাড়িটি তৈরি করেছিলেন, জেডোয়াকোর ঠাকুর বাড়ির আদর্শ এই বাড়ি নির্মিত, বৈষ্ণোবে বাবু মন্ডো হিমালয় মাগুয়ার পথে রবীন্দ্রনাথ ঠাকুর এখানে কিছুদিন বাস করেন, এখন বাড়িটির অধানে কামকিছু বেইজে নির্মিত একটি বিমূর্তি তাকায় রয়েছে, মূর্তিটির নাম 'অনিবার' শিখা,

□ জাতিমজনা :- মহর্ষি দেবেন্দ্রনাথ ঠাকুর মখন বাবুপুরের জমিদার বাড়িতে নিমন্ত্রণ রুচ্যা করতে আসছিলেন তখন সেই জাতিমজনায় কিছুকাল বিশ্রাম নেন, এখানে তিনি প্রানের অগম্য মনের স্যান্টি পেয়েছিলেন, সেইসময়ে তিনি জমিদার বাবু বগজ থেকে খোন অংশ দিতে ২০ বিয়া জমি পাড়া করেন, তেই দুই জাতিম সাড় অজে নেয়, বর্তমানে এখানে হুতি নুস জাতিম-সাড়ে চাড়া বোপান করা হয়েছে,

□ তিনপায়স ও অম্বুজু :- ঠপাখনা গুড়ের চিক-পূর্ব দিকে প্রকাশ্য একটি বর্ডাড়ে বোবা জেয়সাটির নাম তিনপায়স, জেলা মাথ-পূর্বে এখানে একটি পুরের ছিল, পরবর্তীকালে পুরের চিকে এটি করে বাতাম তৈরি হয়, মহর্ষি দেবেন্দ্রনাথ ঠাকুর এখানে স্টিাম করতেন, স্যান্টিনিকেতন বাড়ির দক্ষিণে আম-সাড়ে বোবা জেয়সাটি অম্বুজু নামে খ্যাত, রবীন্দ্রনাথ ঠাকুর নাবেন পুরকার-মাগুয়ার পর-জাতি এখানেই অত্রবর্তিত করা হয়,

□ বিদ্যা (রবীন্দ্রভবন) :- ঠপুয়ালের প্রক্ষে-পাথর-পাথে দেওনা বাড়িটি বিদ্যা বা রবীন্দ্রভবন, এখানে রবীন্দ্র-অত্রই শালনা রয়েছে, এই বাড়ি-১৮৬২ সালে রবীন্দ্র-জন্ম সেরবে তৈরি হয়েছিল, হাম্মাত্তার অজে রবীন্দ্রনাথের ব্যবহৃত কঁ, নিজেই কঁ এবং রবীন্দ্রনাথ অধ্বর্তে লখা বিভিন্ন লেখকের বই, রবীন্দ্র নাম ঠাকুর এবং অন্যান্য শিল্পীদের কলে রবীন্দ্রসংগীত ও রবীন্দ্র কবিতার-ক্যাগেট-ডিকু রয়েছে, লোনা-নদ্রিগা, অত্রবাহপত্রের-বাজাই অত্রস-এবু দেশ-বিদেশের বিভিন্ন ভাষায় রবীন্দ্রসংগীতের অনুবাদ " "

Soma Roy,  
Principal  
Serampore Girls' College  
Serampore, Hooghly

Signature of Principal

Project work/field work/ internships  
Name of Course: Plant Diversity II  
Code: BOTG-CC-2-2-P  
DEPT: Botany  
2022-2023

## Criteria 1.3.2



## Serampore Girls College

13, T.C. Goswami Street,  
Serampore, Hooghly – 712201, West Bengal  
Re- Accredited by NAAC : Grade B (2nd Cycle)  
Email: [serampore\\_girls\\_college@yahoo.co.in](mailto:serampore_girls_college@yahoo.co.in)  
Website: [www.seramporegirlscollege.org](http://www.seramporegirlscollege.org)



## FIELD WORK REPORT 2022-2023 (BOTANY)

### SEMESTER-II

- **Name of the course:** Plant diversity II
- **Date:** 16/05/2023
- **Objective:** This type of tour is organized to aware students about local plants, to know their scientific background and give them practical knowledge about collection, identification of wild angiosperms and preparation of herbarium specimen.
- **Code of the course:** BOTG-CC-2-2-P
- **No. of students attended:** 04
- **Location of Visit:** Chinsurah, Hooghly.
- **Outcome:** Students of semester II took part enthusiastically to fulfil our goal, they learned about different groups of angiosperms, their habit, and habitat, beneficial or harmful effects on environment.
- **Guided by:** Dr. Madhusree Halder, Department of Botany, Serampore Girls' College.

Soma Roy,  
Principal  
Serampore Girls' College  
Serampore, Hooghly

Signature of Principal



### Syllabus of 2<sup>nd</sup> semester BOTG-CC2/GE2

PRACTICAL- PLANT DIVERSITY II (PTERIDOPHYTES, GYMNOSPERMS, PALAEOBOTANY,  
MORPHOLOGY AND TAXONOMY) (BOT-G-CC-2-2-P)  
(Credits 2)

1. Dissection, drawing and labelling, description of angiospermic plants and floral parts, floral formula and floral diagram, identification (family) from the following families: Leguminosae (Fabaceae), Malvaceae, Solanaceae, Labiatea (Lamiaceae), Acanthaceae.
2. **Identification with reasons:**  
Macroscopic specimens of *Selaginella* and *Pteris*, male and female strobilus of *Cycas* and *Pinus*, Anatomical slides (stellar types, transfusion tissue, sieve tube, sunken stomata, lenticels), inflorescence types.
3. **Spot identification** of the following Angiospermic plants (scientific names and families): *Sida rhombifolia* (Malvaceae), *Abutilon indicum* (Malvaceae), *Cassia sophera* (Fabaceae), *Tephrosia halimtonii* (Fabaceae), *Crotolaria palida* (Fabaceae), *Coccinia grandis* (Cucurbitaceae), *Solanum indicum* (Solanaceae), *Nicotiana plumbagenifolia* (Solanaceae), *Leucas aspera* (Lamiaceae), *Leonurus sibiricus* (Lamiaceae), *Parthenium hysterophorus* (Asteraceae), *Tridax procumbense* (Asteraceae), *Eclipta prostrate* (Asteraceae), *Eragrostis tenella* (Poaceae), *Chrysopogon aciculatus* (Poaceae), *Eleusine indica* (Poaceae), *Vanda taesellata* (Orchidaceae).
4. **Laboratory records:** Laboratory note books (regularly signed) and slides (prepared in class) are to be submitted at the time of Practical Examination. Regular attendance in the class must be credited.
5. **Field excursion:** Local Excursions (at least two including one to Acharya Jagadish Chandra Bose Botanic Garden, Shibpur, Howrah)
6. **Field Records:** Field note book and 15 herbarium sheets of common Angiospermic weeds are to be prepared and submitted at the time of Practical Examination. Regular attendance in the class must be credited.

Soma Roy,  
Principal  
Serampore Girls' College  
Serampore, Hooghly

Signature of Principal

# Serampore Girls' College

13, T.C. Goswami Street Serampore Hooghly - 712201 West Bengal

## NAAC Criteria 1.3.2



### Attendance sheet

**SERAMPORE GIRLS' COLLEGE**  
DEPARTMENT OF BOTANY  
Semester-II  
Student attendance sheet

Program: Local excursion at chinsurah      Date: 16/5/2023

| Sl. No. | Roll Number | Semester | Signature of the student |
|---------|-------------|----------|--------------------------|
| 1.      | 22777       | II       | Koyal Barik              |
| 2.      | 22782       | II       | Puja Shree               |
| 3.      | 22790       | II       | Shoufi Kumari            |
| 4.      | 22778       | II       | Neha Singh               |
|         |             |          |                          |
|         |             |          |                          |

Mrida 16/5/2023  
Department of Botany  
Serampore Girls' College  
Serampore, Hooghly

Soma Roy,  
Principal  
Serampore Girls' College  
Serampore, Hooghly

Signature of Principal

# Serampore Girls' College

13, T.C. Goswami Street Serampore Hooghly - 712201 West Bengal

## NAAC Criteria 1.3.2



### PHOTOS OF THE EVENT



*Soma Roy.*  
Principal  
Serampore Girls' College  
Serampore, Hooghly

Signature of Principal

# Serampore Girls' College

13, T.C. Goswami Street Serampore Hooghly - 712201 West Bengal

## NAAC Criteria 1.3.2



### PHOTOS OF THE EVENT

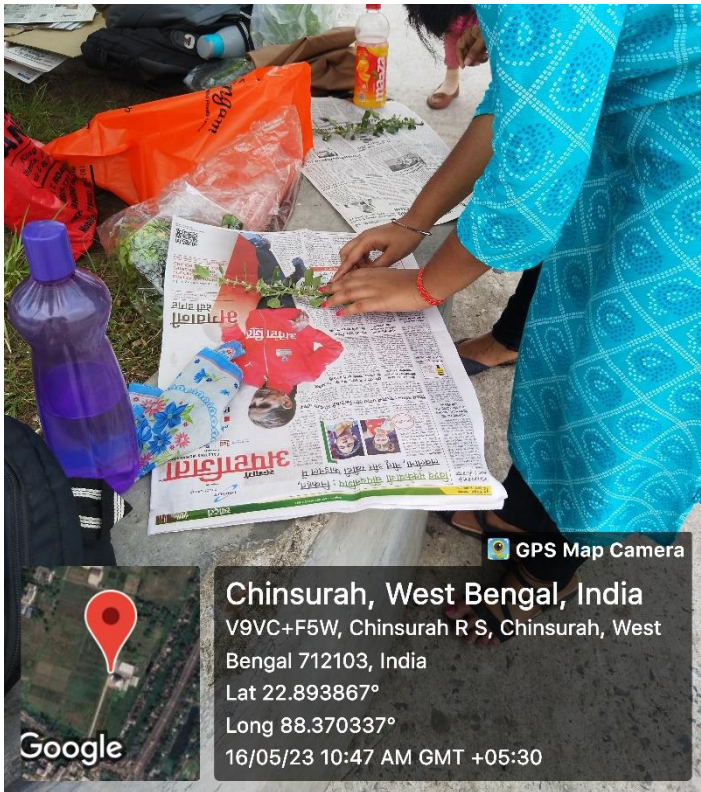

Soma Roy.  
Principal  
Serampore Girls' College  
Serampore, Hooghly

Signature of Principal

# Serampore Girls' College

13, T.C. Goswami Street Serampore Hooghly - 712201 West Bengal

## NAAC Criteria 1.3.2



### PHOTOS OF THE EVENT



Soma Roy,  
Principal  
Serampore Girls' College  
Serampore, Hooghly

Signature of Principal

Project work/field work/ internships  
Name of Course: Economic Botany  
Code: BOTG-DSE-B-6-1-P  
DEPT: Botany  
2022-2023

## Criteria 1.3.2



## Serampore Girls College

13, T.C. Goswami Street,  
Serampore, Hooghly – 712201, West Bengal  
Re- Accredited by NAAC : Grade B (2nd Cycle)  
Email: [serampore\\_girls\\_college@yahoo.co.in](mailto:serampore_girls_college@yahoo.co.in)  
Website: [www.seramporegirlscollege.org](http://www.seramporegirlscollege.org)



## FIELD WORK REPORT 2022-2023 (BOTANY)

### Report on field visit

### SEMESTER-VI

- **Name of the course:** Economic Botany
- **Date:** 16/05/2023
- **Objective:** Field visit is a compulsory part of B.Sc Botany (General) degree course of semester VI under CBCS curriculum. Objective of this type of tour is to aware students about the cultivation method, timing and every minute details of the cultivated plants and its importance to our society.
- **Code of the course:** BOTG-DSE-B-6-1-P
- **No. of students attended:** 05
- **Location of Visit:** Rice research station, Chinsurah, Hooghly.
- **Outcome:** Students of semester VI took part enthusiastically to fulfil our goal, they experienced different practical facts about our staple food crop and its socio-economic value.
- **Guided by:** Dr. Madhusree Halder, Department of Botany, Serampore Girls' College.

*Soma Roy*  
Principal  
Serampore Girls' College  
Serampore, Hooghly

Signature of Principal



### Syllabus of 6<sup>th</sup> semester BOTG-DSE-B-6-1

#### DSE B

#### ECONOMIC BOTANY (BOT-G-DSE-B-6-3-TH)

#### THEORETICAL (Credits 4, Lectures 60)

1. Origin of cultivated plants: 1.1 Concepts of centres of origin and their importance with reference to Vavilov's work.  
.....12 lectures
2. Rice- origin, morphology and uses.  
.....12 lectures
3. Legumes: General account with special reference to *Vigna*.  
.....8 lectures
4. Beverages: Tea- morphology, processing and uses.  
.....12 lectures
5. Study of the following economically important plants (Scientific names, families, parts used and importance): 5.1 Cereals- Rice, wheat, 5.2 Pulses- Mong, gram, 5.3 Spices- Ginger, cumin, 5.4 Beverages- Tea, coffee, 5.5 Medicinal plants- Cinchona, neem, Ipecac, Vasaka, 5.6 Oil yielding plants- Mustard, groundnut, coconut, 5.7 Vegetables- Potato, raddish, bottle gourd, cabbage, 5.8 Fibre yielding plants- Cotton, jute, 5.9 Timber yielding plants- Teak, Sal 5.10 Fruits- Mango, apple, 5.11 Sugar yielding plant- Sugarcane.  
.....16 lectures

#### PRACTICAL- ECONOMIC BOTANY (BOT-G-DSE-B-6-3-P)

#### (Credits 2)

1. Study of economically important plants (rice/jute/ tea) through herbarium specimens and field study.
2. Study of cultivation practices in field and submission of report.
3. Study of local economically important plants and submission of report with photographs.

Soma Roy,  
Principal  
Serampore Girls' College  
Serampore, Hooghly

Signature of Principal

# Serampore Girls' College

13, T.C. Goswami Street Serampore Hooghly - 712201 West Bengal

## NAAC Criteria 1.4.1



### NOTICE

Serampore Girls' College  
(Estd. 1891)  
Accredited by NAAC  
13, T. C. GOSWAMI STREET, SERAMPORE, HOOGHLY, PIN-712 201, WEST BENGAL.  
Ph: (033) 2652 9334 • (033) 26527850 (Principal) • 26623723 (Office) • 2652-0088  
E-mail : science@seramporegirlscollege.org • sgc\_srdtst@gmail.com

DEPARTMENT OF BIO-SCIENCE

Ref No. \_\_\_\_\_ Date 10/05/2023

**NOTICE**

Students of semester VI, Bio science general are hereby informed that there is a Field study organized from Department of Botany Serampore Girls College, at Chinsurah Rice Research Station, Hooghly on 16/05/2023 All students are instructed to attend the study tour. You must carry a note book, pen, camera, College Id card with you.

Mrida 10/5/23  
Signature of Teacher (s)

Department of Botany  
Serampore Girl's College  
Serampore, Hooghly

Soma Roy,  
Principal  
Serampore Girls' College  
Serampore, Hooghly

Signature of Principal

# Serampore Girls' College

13, T.C. Goswami Street Serampore Hooghly - 712201 West Bengal

## NAAC Criteria 1.4.1



### Attendance sheet

**SERAMPORE GIRLS' COLLEGE**  
DEPARTMENT OF BOTANY

Student attendance sheet

Program: Field study at Rice Research station  
Chinsurah, Hooghly

Date: 16/05/2023

| Sl. No. | Roll Number | Semester        | Signature of the student |
|---------|-------------|-----------------|--------------------------|
| 1.      | 20692       | 6 <sup>th</sup> | June Ghosh               |
| 2.      | 20696       | 6 <sup>th</sup> | Makima Chaki             |
| 3.      | 20699       | 6 <sup>th</sup> | Jayshree Debnath         |
| 4.      | 20698       | 6 <sup>th</sup> | Anarna Das               |
| 5.      | 20697       | 6 <sup>th</sup> | Prithi Maji              |
| 6.      |             |                 |                          |

*M. Roy*  
16.05.2023  
Department of Botany  
Serampore Girls' College  
Serampore, Hooghly

*Soma Roy*  
Principal  
Serampore Girls' College  
Serampore, Hooghly

Signature of Principal

# Serampore Girls' College

13, T.C. Goswami Street Serampore Hooghly - 712201 West Bengal

## NAAC Criteria 1.4.1



### PHOTOS OF THE EVENT

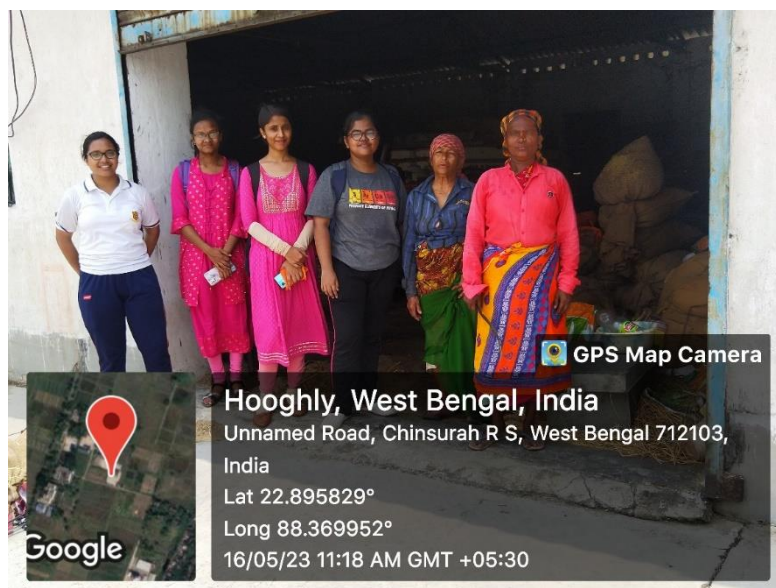

*Soma Roy.*  
Principal  
Serampore Girls' College  
Serampore, Hooghly

Signature of Principal

# Serampore Girls' College

13, T.C. Goswami Street Serampore Hooghly - 712201 West Bengal

## NAAC Criteria 1.4.1

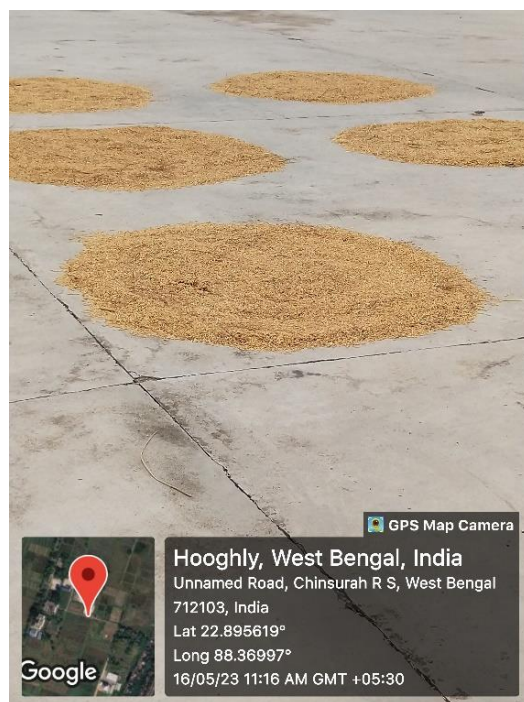
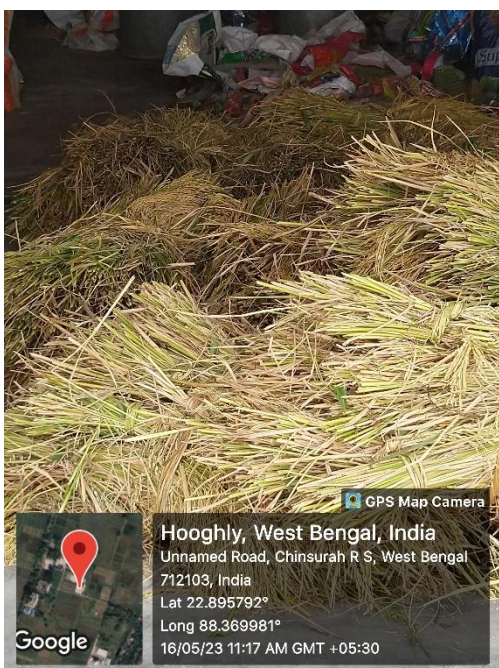

Soma Roy,  
Principal  
Serampore Girls' College  
Serampore, Hooghly

Signature of Principal

Project work/field work/ internships  
Name of Course: ENVIRONMENTAL STUDIES  
Code: AECC 2 (General)  
Course: Environmental Science  
2022-2023

## Criteria 1.3.2



## Serampore Girls College

13, T.C. Goswami Street,  
Serampore, Hooghly – 712201, West Bengal  
Re- Accredited by NAAC : Grade B (2nd Cycle)  
Email: [serampore\\_girls\\_college@yahoo.co.in](mailto:serampore_girls_college@yahoo.co.in)  
Website: [www.seramporegirlscollege.org](http://www.seramporegirlscollege.org)

# Serampore Girls' College

13, T.C. Goswami Street Serampore Hooghly - 712201 West Bengal

## NAAC Criteria 1.3.1



## PROJECT WORK REPORT 2022-2023

### REPORT ON PROJECT WORK OF ENVIRONMENTAL STUDIES (AECC 2)

Academic Session: 2022-2023

SEMSTER: II ( GEN)

Name of Course: ENVIRONMENTAL STUDIES

Code: AECC 2

Location: Serampore Girls' College, WEST BENGAL

#### Course Objective:

Students will learn

- to study local birds and plants

**Date of report submission:** 23/06/2023 and 24/06/2023

**Duration:** 6 months ( 1 semester)

**students enrolled:** 313

**Student submitted:** 313

#### Guided by:

- Dr. Mayurakshi Nag, ( Department of Mathematics, Serampore Girls' College)
- Dr. Ananya Ali ( Department of Zoology, Serampore Girls' College)

#### Course Outcome:

- Students gathered knowledge about local birds and plants by doing this project.

Soma Roy,  
Principal  
Serampore Girls' College  
Serampore, Hooghly

# Serampore Girls' College

( Estd. : 1981 )

Accredited by NAAC

13, T. C. GOSWAMI STREET, SERAMPORE, HOOGHLY. PIN - 712 201, WEST BENGAL.  
Ph: (033) 2652 9334 • (033) 26527850 (Principal) • 26623723 (Office) • 2652-0008  
E-mail : science@seramporegirlscollege.org • sgc.scdept@gmail.com

## Department of SCIENCE

Ref. No. ....

Date. 15/05/23

# NOTICE (ENVS)

This is hereby being notified to all the students of semester-II general, that a project report needs to be submitted to complete their AECC II course 2023.

Topic : Description of local avian (birds) fauna or flora (Tree/plant) [at least 5-8 species] and their importance in local environment

Word limit : 2000 (handwritten/printed/typed format)

Submission date: to be announced, later.

*Mayankshi Roy* 15/05/2023

Department of Science  
Serampore Girls' College

*Soma Roy.*  
Principal  
Serampore Girls' College  
Serampore, Hooghly

# Serampore Girls' College

( Estd. : 1981 )

Accredited by NAAC

13, T. C. GOSWAMI STREET, SERAMPORE, HOOGHLY. PIN -712 201, WEST BENGAL.  
Ph: (033) 2652 9334 • (033) 26527850 (Principal) • 26623723 (Office) • 2652-0008  
E-mail : science@seramporegirlscollege.org • sgc.scdept@gmail.com

## Department of SCIENCE

Ref. No. ....

Date. 15/06/2023

## NOTICE (ENVS)

This is hereby being notified to all the students of semester II general that the ENVS (AECC 2) project report submission and viva-voce dates have been finalized as mentioned below for respective college roll no. Please mention CU roll no and reg no on the top of the project report and must carry previous semester's admit card on that day.

| Submission date(s) | Time                | College Roll No |
|--------------------|---------------------|-----------------|
| 23/06/2023         | 11:00 am – 01:00 pm | 22400-22505     |
| 23/06/2023         | 02:00 pm – 04:00 pm | 22506-22610     |
| 24/06/2023         | 11:00 am – 01:00 pm | 22611-22710     |
| 24/06/2023         | 02:00 pm – 03:30 pm | 22711-22804     |

*[Signature]*  
15/06/23

15/06/2023

Department of Science  
Serampore Girls' College

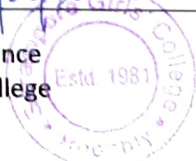

*[Signature]*  
Principal  
Serampore Girls' College  
Serampore, Hooghly



# UNIVERSITY OF CALCUTTA

## Notification No. CSR/ 12 /18

It is notified for information of all concerned that the Syndicate in its meeting held on 28.05.2018 (vide Item No.14) approved the Syllabi of different subjects in Undergraduate Honours / General / Major courses of studies (CBCS) under this University, as laid down in the accompanying pamphlet:

### List of the subjects

| <u>Sl. No.</u> | <u>Subject</u>  | <u>Sl. No.</u> | <u>Subject</u>   |
|----------------|---|----------------|--|
| 1              | Anthropology (Honours / General)                      | 29             | Mathematics (Honours / General)                                |
| 2              | Arabic (Honours / General)                            | 30             | Microbiology (Honours / General)                               |
| 3              | Persian (Honours / General)                           | 31             | Mol. Biology (General)   |
| 4              | Bengali (Honours / General /LCC2 /AECC1)              | 32             | Philosophy (Honours / General)                                 |
| 5              | Bio-Chemistry (Honours / General)                     | 33             | Physical Education (General)                                   |
| 6              | Botany (Honours / General)                            | 34             | Physics (Honours / General)                                    |
| 7              | Chemistry (Honours / General)                         | 35             | Physiology (Honours / General)                                 |
| 8              | Computer Science (Honours / General)                  | 36             | Political Science (Honours / General)                          |
| 9              | Defence Studies (General)                             | 37             | Psychology (Honours / General)                                 |
| 10             | Economics (Honours / General)                         | 38             | Sanskrit (Honours / General)                                   |
| 11             | Education (Honours / General)                         | 39             | Social Science (General)                                       |
| 12             | Electronics (Honours / General)                       | 40             | Sociology (Honours / General)                                  |
| 13             | English ((Honours / General/ LCC1/ LCC2/AECC1)        | 41             | Statistics (Honours / General)                                 |
| 14             | Environmental Science (Honours / General)             | 42             | Urdu (Honours / General /LCC2 /AECC1)                          |
| 15             | Environmental Studies (AECC2)                         | 43             | Women Studies (General)  |
| 16             | Film Studies ( General)                               | 44             | Zoology (Honours / General)                                    |
| 17             | Food Nutrition (Honours / General)                    | 45             | Industrial Fish and Fisheries – IFFV (Major)                   |
| 18             | French (General)                                      | 46             | Sericulture – SRTV (Major)                                     |
| 19             | Geography (Honours / General)                         | 47             | Computer Applications – CMAV (Major)                           |
| 20             | Geology (Honours / General)                           | 48             | Tourism and Travel Management – TTMV (Major)                   |
| 21             | Hindi (Honours / General /LCC2 /AECC1)                | 49             | Advertising Sales Promotion and Sales Management –ASPV (Major) |
| 22             | History (Honours / General)                           | 50             | Communicative English –CMEV (Major)                            |
| 23             | Islamic History Culture (Honours / General)           | 51             | Clinical Nutrition and Dietetics CNDV (Major)                  |
| 24             | Home Science Extension Education (General)            | 52             | Bachelor of Business Administration (BBA) (Honours)            |
| 25             | House Hold Art (General)                              | 53             | Bachelor of Fashion and Apparel Design – (B.F.A.D.) (Honours)  |
| 26             | Human Development (Honours / General)                 | 54             | Bachelor of Fine Art (B.F.A.) (Honours)                        |
| 27             | Human Rights (General)                                | 55             | B. Music (Honours / General) and Music (General)               |
| 28             | Journalism and Mass Communication (Honours / General) |                |  |

The above shall be effective from the academic session 2018-2019.

SENATE HOUSE  
KOLKATA-700073  
The 4<sup>th</sup> June, 2018

*Paul*  
4/6/18  
(Dr. Santanu Paul)  
Deputy Registrar

# University of Calcutta

## *Under Graduate Curriculum under Choice Based Credit System (CBCS)*

### Syllabus for Ability Enhancement Compulsory Course-2 (AECC-2) in **Environmental Studies**

Semester-2

**Total Marks-100(Credit -2)**

(50 Theory-MCQ type + 30 Project + 10 Internal Assessment + 10 Attendance)

[Marks obtained in this course will be taken to calculate SGPA & CGPA]

### **Theory**

|   |            |
|---|------------|
| <b>Unit 1 Introduction to environmental studies</b>   | 2 lectures |
| <ul style="list-style-type: none"><li>•Multidisciplinary nature of environmental studies;</li><li>•Scope and importance; Concept of sustainability and sustainable development.</li></ul>   |            |
| <b>Unit 2 Ecology and Ecosystems</b>  | 6 lectures |
| <ul style="list-style-type: none"><li>•Concept of ecology and ecosystem, Structure and function of ecosystem; Energy flow in an ecosystem; food chains, food webs; Basic concept of population and community ecology; ecological succession.</li><li>•Characteristic features of the following:<ol style="list-style-type: none"><li>a) Forest ecosystem</li><li>b) Grassland ecosystem</li><li>c) Desert ecosystem</li><li>d) Aquatic ecosystems (ponds, streams, lakes, wetlands, rivers, oceans, estuaries)</li></ol></li></ul>  |            |
| <b>Unit 3 Natural Resources</b>   | 8 lectures |
| <ul style="list-style-type: none"><li>• Concept of Renewable and Non-renewable resources</li><li>• Land resources and land use change; Land degradation, soil erosion and desertification.</li><li>•Deforestation: Causes, consequences and remedial measures</li><li>•Water: Use and over-exploitation of surface and ground water, floods, droughts, conflicts over water (international &amp; inter-state).</li><li>•Energy resources: Environmental impacts of energy generation, use of alternative and nonconventional energy sources, growing energy needs.</li></ul>  |            |
| <b>Unit 4 Biodiversity and Conservation</b>   | 8 lectures |
| <ul style="list-style-type: none"><li>•Levels of biological diversity: genetic, species and ecosystem diversity;</li><li>• Biogeographic zones of India; Biodiversity patterns and global biodiversity hot spots</li><li>•India as a mega-biodiversity nation; Endangered and endemic species of India</li><li>•Threats to biodiversity: Habitat loss, poaching of wildlife, man-wildlife conflicts, biological invasions;</li><li>•Conservation of biodiversity: In-situ and Ex-situ conservation of biodiversity.</li><li>•Ecosystem and biodiversity services: Ecological, economic, social, ethical, aesthetic and Informational value.</li></ul> |            |
| <b>Unit 5 Environmental Pollution</b>   | 8 lectures |
| <ul style="list-style-type: none"><li>• Environmental pollution: concepts and types,</li><li>• Air, water, soil, noise and marine pollution- causes, effects and controls</li><li>• Concept of hazardous waste and human health risks</li><li>• Solid waste management: Control measures of Municipal, biomedical and e-waste.</li></ul>  |            |

|   |                     |
|---|---------------------|
| <b>Unit 6 Environmental Policies and Practices</b>  | 7 lectures          |
| <ul style="list-style-type: none"> <li>•Climate change, global warming, ozone layer depletion, acid rain and their impacts on human communities and agriculture</li> <li>•Environment Laws: Wildlife Protection Act; Forest Conservation Act. Water (Prevention and control of Pollution) Act; Air (Prevention &amp; Control of Pollution) Act; Environment Protection Act; Biodiversity Act.</li> <li>•International agreements: Montreal Protocol, Kyoto protocol and climate negotiations; Convention on Biological Diversity (CBD).</li> <li>•Protected area network, tribal populations and rights, and human wildlife conflicts in Indian context.</li> </ul> |                     |
| <b>Unit 7 Human Communities and the Environment</b>   | 6 lectures          |
| <ul style="list-style-type: none"> <li>•Human population growth: Impacts on environment, human health and welfare.</li> <li>•Case studies on Resettlement and rehabilitation.</li> <li>• Environmental Disaster: Natural Disasters-floods, earthquake, cyclones, tsunami and landslides; Manmade Disaster- Bhopal and Chernobyl.</li> <li>•Environmental movements: Bishnois, Chipko, Silent valley, Big dam movements.</li> <li>•Environmental ethics: Role of gender and cultures in environmental conservation.</li> <li>•Environmental education and public awareness</li> </ul>  |                     |
| <b>Project/ Field work</b>  | Equal to 5 lectures |
| <ul style="list-style-type: none"> <li>•Visit to an area to document environmental assets: Natural resources/flora/fauna, etc.</li> <li>•Visit to a local polluted site-Urban/Rural/Industrial/Agricultural.</li> <li>•Study of common plants, insects, fish, birds, mammals and basic principles of identification.</li> <li>•Study of ecosystems-pond, river, wetland, forest, estuary and agro ecosystem.</li> </ul>   |                     |
| <b>Total</b>  | <b>50 Lectures</b>  |

**Suggested Reading:**

Asthana, D. K. (2006). *Text Book of Environmental Studies*. S. Chand Publishing.

Basu, M., Xavier, S. (2016). *Fundamentals of Environmental Studies*, Cambridge University Press, India

Basu, R. N., (Ed.) (2000). *Environment*. University of Calcutta, Kolkata

Bharucha, E. (2013). *Textbook of Environmental Studies for Undergraduate Courses*. Universities Press.

De, A.K., (2006). *Environmental Chemistry*, 6th Edition, New Age International, New Delhi.

Mahapatra, R., Jeevan, S.S., Das, S. (Eds) (2017). *Environment Reader for Universities*, Centre for Science and Environment, New Delhi.

Masters, G. M., & Ela, W. P. (1991). *Introduction to environmental engineering and science*. Englewood Cliffs, NJ: Prentice Hall.

Odum, E. P., Odum, H. T., & Andrews, J. (1971). *Fundamentals of ecology*. Philadelphia: Saunders.

Sharma, P. D., & Sharma, P. D. (2005). *Ecology and environment*. Rastogi Publications.

**ENVS project submission : 2nd sem BA BSC General 2023**

| Sl            | Roll             | Name                            | CU Roll                   | CU Reg                      | Signature          | Marks |
|---------------|------------------|---------------------------------|---------------------------|-----------------------------|--------------------|-------|
| 1             | 22615            | RIYA DEY                        | 222614-12-0001            | 614-1211-0312-22            | Riya Dey           |       |
| 2             | 22442            | BARNALI DAS                     | 222614-12-0002            | 614-1211-0313-22            | Barnali Das        |       |
| 3             | 22614            | RIYA BISWAS                     | 222614-12-0003            | 614-1211-0314-22            | Riya Biswas        |       |
| 4             | 22448            | BHUMIKA BISWAL                  | 222614-12-0004            | 614-1211-0317-22            |                    |       |
| 5             | 22571            | PRITHA GHOSH                    | 222614-12-0005            | 614-1211-0318-22            | Pritha Ghosh       |       |
| <del>6</del>  | <del>22409</del> | <del>ANCHAL SINGH</del>         | <del>222614-12-0006</del> | <del>614-1211-0319-22</del> |                    |       |
| 7             | 22620            | RIYANKA DAS                     | 222614-12-0007            | 614-1211-0320-22            | Riyanka Das        |       |
| 8             | 22705            | SNEHA DAS BAIRAGHYA             | 222614-12-0008            | 614-1211-0321-22            | Sneha Das Bairaghy |       |
| 9             | 22406            | ANAMIKA ROY                     | 222614-12-0009            | 614-1211-0324-22            | Anamika Roy        |       |
| 10            | 22684            | SHARMISTA SANTRA                | 222614-12-0010            | 614-1211-0325-22            | Sharmista Santra   |       |
| <del>11</del> | <del>22664</del> | <del>SANDHITA CHAKRABORTY</del> | <del>222614-12-0011</del> | <del>614-1211-0326-22</del> |                    |       |
| 12            | 22731            | SUMITRA RAJBHAR                 | 222614-12-0012            | 614-1211-0327-22            |                    |       |
| 13            | 22641            | SABANA YEASMIN                  | 222614-12-0013            | 614-1211-0328-22            |                    |       |
| 14            | 22728            | SUMAN KUMARI SINGH              | 222614-12-0014            | 614-1211-0330-22            | Suman Kumari Singh |       |
| 15            | 22612            | RITU MISHRA                     | 222614-12-0015            | 614-1211-0332-22            | Ritu Mishra        |       |
| 16            | 22753            | TANUSHREE PAUL                  | 222614-12-0016            | 614-1211-0334-22            | Tanushree Paul     |       |
| 17            | 22602            | RIJUTA SAHA                     | 222614-12-0017            | 614-1211-0337-22            | Rijuta Saha        |       |
| 18            | 22490            | KANKANA PAL                     | 222614-12-0018            | 614-1211-0338-22            | Kankana Pal        |       |
| 19            | 22542            | NEHA KHATUN                     | 222614-12-0019            | 614-1211-0345-22            | Neha Khatun        |       |
| 20            | 22650            | SAHIN PARVIN                    | 222614-12-0020            | 614-1211-0346-22            | Sahin Parvin       |       |
| 21            | 22441            | AYESA KHATUN                    | 222614-12-0021            | 614-1211-0348-22            | Ayesa Khatun       |       |
| 22            | 22403            | AIRIN KHATUN                    | 222614-12-0022            | 614-1211-0349-22            | Airin Khatun       |       |
| 23            | 22473            | IPSITA DEY                      | 222614-12-0023            | 614-1211-0352-22            | Ipsita Dey         |       |
| 24            | 22599            | RANITA GARANG                   | 222614-12-0024            | 614-1211-0353-22            |                    |       |
| 25            | 22687            | SHIVANI PANDEY                  | 222614-12-0025            | 614-1211-0356-22            | Shivani Pandey     |       |
| 26            | 22500            | KOYEL HAZRA                     | 222614-12-0026            | 614-1211-0357-22            | Koyel Hazra        |       |
| 27            | 22729            | SUMANA BAG                      | 222614-12-0027            | 614-1211-0358-22            | Sumana Bag         |       |
| 28            | 22568            | PRAGATI DUTTA                   | 222614-12-0028            | 614-1211-0359-22            | Pragati Dutta      |       |
| 29            | 22726            | SUKRIYA KHATUN                  | 222614-12-0029            | 614-1211-0361-22            | Sukriya Khatun     |       |
| 30            | 22649            | SAHENA YEASMIN                  | 222614-12-0030            | 614-1211-0362-22            | Sahena yeasmin     |       |
| 31            | 22494            | KEYA KOLEY                      | 222614-12-0031            | 614-1211-0363-22            | Keya Koley         |       |
| 32            | 22426            | ARNABI CHALKI                   | 222614-12-0032            | 614-1211-0364-22            | Arnabi Chalki      |       |
| 33            | 22556            | PARAMITA GOLDER                 | 222614-12-0033            | 614-1211-0365-22            | Paramita Golder    |       |
| 34            | 22523            | MOUMITA MALIK                   | 222614-12-0034            | 614-1211-0367-22            | Moumita malik      |       |
| 35            | 22532            | MUSKAN SHAW                     | 222614-12-0035            | 614-1211-0368-22            | Muskan Shaw        |       |
| 36            | 22616            | RIYA GOLDAR                     | 222614-12-0036            | 614-1211-0369-22            | Riya Goldar        |       |
| <del>37</del> | <del>22651</del> | <del>SAHINA PARVIN</del>        | <del>222614-12-0037</del> | <del>614-1211-0371-22</del> |                    |       |
| 38            | 22567            | POULAMI GHOSH                   | 222614-12-0038            | 614-1211-0372-22            | Poulami Ghosh      |       |

## ENVS project submission : 2nd sem BA BSC General 2023

| Roll          | Name                                  | CU Roll                   | CU Reg                      | Signature          | Marks |
|---------------|---------------------------------------|---------------------------|-----------------------------|--------------------|-------|
| <del>9</del>  | <del>22519 MOSAMMAT SAIRIN NESA</del> | <del>222614-12-0039</del> | <del>614-1211-0373-22</del> |                    |       |
| 10            | 22688 SHREYA GHOSH                    | 222614-12-0040            | 614-1211-0374-22            | Shreya Ghosh       |       |
| 41            | 22685 SHILPA DEY                      | 222614-12-0041            | 614-1211-0376-22            | Shilpa Dey         |       |
| 42            | 22582 PRIYA SHAW                      | 222614-12-0042            | 614-1211-0377-22            | Priya Shaw         |       |
| <del>43</del> | <del>22505 LIJA KOLEY</del>           | <del>222614-12-0043</del> | <del>614-1211-0378-22</del> |                    |       |
| 44            | 22619 RIYA MANNA                      | 222614-12-0044            | 614-1211-0380-22            | Riya Manna         |       |
| <del>45</del> | <del>22512 MAUBANI PAUL</del>         | <del>222614-12-0045</del> | <del>614-1211-0381-22</del> |                    |       |
| 46            | 22513 MILI BAG                        | 222614-12-0046            | 614-1211-0382-22            | Mili Bag           |       |
| 47            | 22507 MADHUMITA MONDAL                | 222614-12-0047            | 614-1211-0383-22            | Madhumita Mondal   |       |
| 48            | 22677 SAYANTIKA KAR                   | 222614-12-0048            | 614-1211-0384-22            | Sayantika Kar      |       |
| 49            | 22759 TITHI DAS                       | 222614-12-0049            | 614-1211-0385-22            | Tithi Das          |       |
| 50            | 22401 AFROZA KHATUN                   | 222614-12-0050            | 614-1211-0386-22            | Afroza Khatun      |       |
| 51            | 22665 SANDIPA KUMARI RAM              | 222614-12-0051            | 614-1211-0387-22            | Sandipa Kumari Ram |       |
| 52            | 22423 ARATI KUMARI SHAW               | 222614-12-0052            | 614-1211-0388-22            | Arati Kumari Shaw  |       |
| 53            | 22550 NIVEDITA DAS                    | 222614-12-0053            | 614-1211-0389-22            | Nivedita Das       |       |
| 54            | 22416 ANKITA SINGHA                   | 222614-12-0054            | 614-1211-0390-22            | Ankita Singha      |       |
| 55            | 22514 MINATI KARMAKAR                 | 222614-12-0055            | 614-1211-0391-22            | Minati Kar         |       |
| 56            | 22478 JAYA JAISWARA                   | 222614-12-0056            | 614-1211-0392-22            | Jaya Jaiswara      |       |
| 57            | 22457 DIPIKA GHOSH                    | 222614-12-0057            | 614-1211-0393-22            | Dipika Ghosh       |       |
| 58            | 22656 SALMA KHATUN                    | 222614-12-0058            | 614-1211-0394-22            | Salma Khatun       |       |
| 59            | 22764 TUHINA KHATUN                   | 222614-12-0059            | 614-1211-0395-22            | Tuhina Khatun      |       |
| 60            | 22607 RIMPA POREL                     | 222614-12-0060            | 614-1211-0396-22            | Rimpa Porel        |       |
| 61            | 22469 HABIBA KHATUN                   | 222614-12-0061            | 614-1211-0397-22            | Habiba Khatun      |       |
| 62            | 22603 RIKTA PAL                       | 222614-12-0062            | 614-1211-0398-22            | Rikta Pal          |       |
| 63            | 22461 DIYA PAL                        | 222614-12-0063            | 614-1211-0400-22            | Diya Pal           |       |
| 64            | 22526 MOUPRIYA DAS                    | 222614-12-0064            | 614-1211-0401-22            | Moupriya Das       |       |
| 65            | 22573 PRITI BAHADUR                   | 222614-12-0065            | 614-1211-0402-22            | Priti Bahadur      |       |
| 66            | 22608 RINI KARMAKAR                   | 222614-12-0066            | 614-1211-0404-22            | Rini Karமாகar      |       |
| <del>67</del> | <del>22437 ASMITA PATRA</del>         | <del>222614-12-0067</del> | <del>614-1211-0405-22</del> |                    |       |
| 68            | 22562 PINKI SAMANTA                   | 222614-12-0068            | 614-1211-0407-22            | Pinki Samanta      |       |
| 69            | 22694 SHREYASHRI KUNDU                | 222614-12-0069            | 614-1211-0410-22            | Shreyashri Kundu   |       |
| 70            | 22407 ANANYA BHANDARY                 | 222614-12-0070            | 614-1211-0411-22            |                    |       |
| 71            | 22509 MAMALI PRADHAN                  | 222614-12-0071            | 614-1211-0412-22            | Mamali Pradhan     |       |
| 72            | 22596 RAJANI GUPTA                    | 222614-12-0072            | 614-1211-0413-22            | Rajani Gupta       |       |
| 73            | 22579 PRIYA MANNA                     | 222614-12-0073            | 614-1211-0414-22            | Priya Manna        |       |
| 74            | 22754 TANUSREE DAS                    | 222614-12-0074            | 614-1211-0416-22            | Tanusree Das       |       |
| 75            | 22447 BATTULA KALPANA                 | 222614-12-0075            | 614-1211-0418-22            | Battula Kalpana    |       |
| 76            | 22575 PRITI SHARMA                    | 222614-12-0076            | 614-1211-0420-22            | Priti Sharma       |       |

## ENVS project submission : 2nd sem BA BSC General 2023

| Sl  | Roll             | Name                 | CU Roll                   | CU Reg                      | Signature        | Marks |
|-----|------------------|----------------------|---------------------------|-----------------------------|------------------|-------|
| 77  | 22589            | PUJA RAUTH           | 222614-12-0077            | 614-1211-0421-22            | Puja Rauth       |       |
| 78  | 22417            | ANOWARA KHATUN       | 222614-12-0078            | 614-1211-0423-22            | Anowara Khatun   |       |
| 79  | 22725            | SUKANYA BERA         | 222614-12-0079            | 614-1211-0424-22            | Sukanya Bera     |       |
| 80  | 22517            | MONALISHA PAUL       | 222614-12-0080            | 614-1211-0426-22            | Mona Kishapaul   |       |
| 81  | 22749            | TAMANA PARWEEN       | 222614-12-0081            | 614-1211-0427-22            | Tamana Parween   |       |
| 82  | 22627            | RUKSAR KHATUN        | 222614-12-0082            | 614-1211-0428-22            | Ruksar Khatun    |       |
| 83  | <del>22633</del> | <del>RUPSA DAS</del> | <del>222614-12-0083</del> | <del>614-1211-0429-22</del> |                  |       |
| 84  | 22748            | SWETA KUMARI         | 222614-12-0084            | 614-1211-0430-22            | Swe ta Kumari    |       |
| 85  | 22673            | SANTANA BARIK        | 222614-12-0085            | 614-1211-0432-22            |                  |       |
| 86  | 22693            | SHREYA PATRA         | 222614-12-0086            | 614-1211-0433-22            | Shreya patra     |       |
| 87  | 22707            | SNEHA MAITY          | 222614-12-0087            | 614-1211-0434-22            | Sneha Maity      |       |
| 88  | 22703            | SNEHA DAS            | 222614-12-0088            | 614-1211-0436-22            | Sneha Das        |       |
| 89  | 22569            | PREETI OJHA          | 222614-12-0089            | 614-1211-0438-22            | Preeti Ojha      |       |
| 90  | 22747            | SWETA GUPTA          | 222614-12-0090            | 614-1211-0439-22            | Sweta Gupta      |       |
| 91  | 22631            | RUNI PANDEY          | 222614-12-0091            | 614-1211-0440-22            | Runi Pandey      |       |
| 92  | 22609            | RINI MAITY           | 222614-12-0092            | 614-1211-0441-22            | Rini Maity       |       |
| 93  | 22611            | RITIKA SINGHA        | 222614-12-0093            | 614-1211-0442-22            | Ritika Singha    |       |
| 94  | 22455            | DEVI CHAKRABORTY     | 222614-12-0094            | 614-1211-0443-22            | Devi Chakraborty |       |
| 95  | 22463            | FARAHANA KHATUN      | 222614-12-0095            | 614-1211-0444-22            | Farahana Khatun  |       |
| 96  | 22515            | MITHU SARKAR         | 222614-12-0096            | 614-1211-0445-22            | Mithu Sarkar     |       |
| 97  | 22667            | SANGITA PATRA        | 222614-12-0097            | 614-1211-0446-22            |                  |       |
| 98  | 22560            | PAYEL POREL          | 222614-12-0098            | 614-1211-0448-22            | payel porel      |       |
| 99  | 22758            | TINA DHARA           | 222614-12-0099            | 614-1211-0449-22            | Tina Dhara       |       |
| 100 | 22674            | SANTOSHI HARI        | 222614-12-0100            | 614-1211-0450-22            | Santoshi Hari    |       |
| 101 | 22456            | DIPA DAS             | 222614-12-0101            | 614-1211-0451-22            | Dipa Das         |       |
| 102 | 22689            | SHREYA KAR           | 222614-12-0102            | 614-1211-0452-22            | Shreya Kar       |       |
| 103 | 22408            | ANANYA PONDA         | 222614-12-0103            | 614-1211-0453-22            | Ananya Ponda     |       |
| 104 | 22487            | KAJAL SHAW           | 222614-12-0104            | 614-1211-0454-22            | Kajal Shaw       |       |
| 105 | 22584            | PRIYASHA GHOSH       | 222614-12-0105            | 614-1211-0455-22            | Priyasha Ghosh   |       |
| 106 | 22736            | SUSHAMA TANTI        | 222614-12-0106            | 614-1211-0456-22            | Sushama Tanti    |       |
| 107 | 22446            | BARSHA KOLEY         | 222614-12-0107            | 614-1211-0458-22            | Barsha Koley     |       |
| 108 | 22524            | MOUMITA SANTRA       | 222614-12-0108            | 614-1211-0459-22            | Moumita Santra   |       |
| 109 | 22521            | MOUMITA DAS          | 222614-12-0109            | 614-1211-0460-22            | Moumita Das      |       |
| 110 | 22658            | SALONI SHAW          | 222614-12-0110            | 614-1211-0461-22            | Saloni Shaw      |       |
| 111 | 22708            | SNEHA MITRA          | 222614-12-0111            | 614-1211-0464-22            | Sneha Mitra      |       |
| 112 | 22445            | BARSHA DHARA         | 222614-12-0112            | 614-1211-0465-22            | Barsha Dhara     |       |
| 113 | <del>22539</del> | <del>NEHA ADAK</del> | <del>222614-12-0113</del> | <del>614-1211-0467-22</del> |                  |       |
| 114 | 22467            | FARJANA YEASMIN      | 222614-12-0114            | 614-1211-0468-22            | Farjana Yeasmin  |       |

## ENVS project submission : 2nd sem BA BSC General 2023

| Roll | Name                             | CU Roll                   | CU Reg                      | Signature        | Marks |
|------|----------------------------------|---------------------------|-----------------------------|------------------|-------|
| 115  | 22644 SABIYA KHATUN              | 222614-12-0115            | 614-1211-0469-22            | Sabiya Khatun    |       |
| 116  | 22414 ANKITA PAL                 | 222614-12-0116            | 614-1211-0470-22            | Ankita Pal       |       |
| 117  | 22503 LABONI DEY                 | 222614-12-0117            | 614-1211-0473-22            | Laboni Dey       |       |
| 118  | 22768 URMI KARMAKAR              | 222614-12-0118            | 614-1211-0474-22            |                  |       |
| 119  | 22646 SABNAM YEASMIN             | 222614-12-0119            | 614-1211-0475-22            | Sabnam Yeasmin   |       |
| 120  | 22766 TUHINA YADAV               | 222614-12-0120            | 614-1211-0476-22            | Tuhina Yadav     |       |
| 121  | 22411 ANJALI PRADHAN             | 222614-12-0121            | 614-1211-0477-22            | Anjali Pradhan   |       |
| 122  | 22488 KAKALI BERA                | 222614-12-0122            | 614-1211-0478-22            | Kakali Bera      |       |
| 123  | 22551 NOOR SABA                  | 222614-12-0123            | 614-1211-0480-22            | Noor Saba        |       |
| 124  | <del>22431 ARPITA PANJA</del>    | <del>222614-12-0124</del> | <del>614-1211-0481-22</del> |                  |       |
| 125  | 22546 NIDHI GHOSH                | 222614-12-0125            | 614-1211-0482-22            | Nidhi Ghosh      |       |
| 126  | 22497 KHOOSHBU TIWARI            | 222614-12-0126            | 614-1211-0483-22            | Khooshbu Tiwari  |       |
| 127  | 22605 RIMPA DAS                  | 222614-12-0127            | 614-1211-0486-22            | Rimpa Das        |       |
| 128  | 22540 NEHA DAS                   | 222614-12-0128            | 614-1211-0487-22            | Neha Das         |       |
| 129  | <del>22402 AFSANA KHATOON</del>  | <del>222614-12-0129</del> | <del>614-1211-0489-22</del> |                  |       |
| 130  | <del>22525 MOUPARNA SANTRA</del> | <del>222614-12-0130</del> | <del>614-1211-0490-22</del> |                  |       |
| 131  | 22428 ARPITA KOLE                | 222614-12-0131            | 614-1211-0491-22            | Arpita Kole      |       |
| 132  | 22489 KANKANA BARICK             | 222614-12-0132            | 614-1211-0492-22            |                  |       |
| 133  | 22495 KEYA MRIDHA                | 222614-12-0133            | 614-1211-0493-22            | Keya mridha      |       |
| 134  | 22534 NANDINI GHOSH              | 222614-12-0134            | 614-1211-0494-22            | Nandini Ghosh    |       |
| 135  | <del>22412 ANKANA BOSE</del>     | <del>222614-12-0135</del> | <del>614-1211-0496-22</del> |                  |       |
| 136  | 22493 KEYA CHAKRABORTY           | 222614-12-0136            | 614-1211-0497-22            | Keya Chakraborty |       |
| 137  | 22613 RIYA ADHIKARY              | 222614-12-0137            | 614-1211-0498-22            | Riya Adhikary    |       |
| 138  | 22590 PUJA YADAB                 | 222614-12-0138            | 614-1211-0499-22            | Puja Yadab       |       |
| 139  | 22723 SUDIPA DAS                 | 222614-12-0139            | 614-1211-0500-22            | Sudipa Das       |       |
| 140  | 22740 SUSMITA ROY                | 222614-12-0140            | 614-1211-0501-22            |                  |       |
| 141  | 22580 PRIYA MANNA                | 222614-12-0141            | 614-1211-0502-22            | Priya Manna      |       |
| 142  | 22711 SNIGDHA SANTRA             | 222614-12-0142            | 614-1211-0503-22            | Snigdha Santra   |       |
| 143  | 22570 PRITHA DAS                 | 222614-12-0143            | 614-1211-0504-22            | Pritha Das       |       |
| 144  | 22760 TITLI DE                   | 222614-12-0144            | 614-1211-0505-22            | Titli de         |       |
| 145  | 22424 ARATI SHARMA               | 222614-12-0145            | 614-1211-0506-22            | Arati Shasima    |       |
| 146  | 22451 BITHIKA SANTRA             | 222614-12-0146            | 614-1211-0507-22            | Bithika Santra   |       |
| 147  | 22735 SUPRIYA ADAK               | 222614-12-0147            | 614-1211-0508-22            | Supriya Adak     |       |
| 148  | 22595 RAI DUTTA                  | 222614-12-0148            | 614-1211-0510-22            | Rai Dutta        |       |
| 149  | <del>22645 SABNAM KHATOON</del>  | <del>222614-12-0149</del> | <del>614-1211-0511-22</del> |                  |       |
| 150  | 22675 SARIA KHATUN               | 222614-12-0150            | 614-1211-0513-22            | Saria Khatun     |       |
| 151  | 22527 MOUSUMI DAS                | 222614-12-0151            | 614-1211-0515-22            | Mousumi Das      |       |
| 152  | 22548 NIKITA DAS                 | 222614-12-0152            | 614-1211-0517-22            | Nikita Das       |       |

## ENVS project submission : 2nd sem BA BSC General 2023

| Sl  | Roll  | Name                | CU Roll        | CU Reg           | Signature      | Marks |
|-----|-------|---------------------|----------------|------------------|----------------|-------|
| 153 | 22717 | SOUMI PATRA         | 222614-12-0153 | 614-1211-0518-22 | Soumi Patra    |       |
| 154 | 22700 | SMRITI PATRA        | 222614-12-0154 | 614-1211-0519-22 | Smriti Patra   |       |
| 155 | 22601 | RATI MAJHI          | 222614-12-0155 | 614-1211-0521-22 |                |       |
| 156 | 22706 | SNEHA DEBNATH       | 222614-12-0156 | 614-1211-0523-22 | Sneha Debnath  |       |
| 157 | 22718 | SOUMITA DAS         | 222614-12-0157 | 614-1211-0524-22 | Soumita Das    |       |
| 158 | 22695 | SHRUTI THAKUR       | 222614-12-0158 | 614-1211-0525-22 | Shruti Thakur  |       |
| 159 | 22433 | ASHIA PARVIN        | 222614-12-0159 | 614-1211-0527-22 | Ashia Parvin   |       |
| 160 | 22522 | MOUMITA KAR         | 222614-12-0160 | 614-1211-0528-22 | Moumita Kar    |       |
| 161 | 22592 | PUNAM SINGH         | 222614-12-0161 | 614-1211-0529-22 | Punam Singh    |       |
| 162 | 22648 | SAHELI SARKAR       | 222614-12-0162 | 614-1211-0530-22 | Saheli Sarkar  |       |
| 163 | 22421 | ANUSHRI SARKAR      | 222614-12-0163 | 614-1211-0533-22 | Anushri Sarkar |       |
| 164 | 22746 | SWETA KUMARI TIWARI | 222614-12-0164 | 614-1211-0536-22 |                |       |
| 165 | 22632 | RUPA PRASAD         | 222614-12-0165 | 614-1211-0537-22 |                |       |
| 166 | 22415 | ANKITA ROY          | 222614-12-0166 | 614-1211-0538-22 | Ankita Roy     |       |
| 167 | 22436 | ASMINA KHATUN       | 222614-12-0167 | 614-1211-0539-22 | Asmina Khatun  |       |
| 168 | 22418 | ANUKTA PYNE         | 222614-12-0168 | 614-1211-0542-22 | Anukta Pyne    |       |
| 169 | 22572 | PRITHA SANTRA       | 222614-12-0169 | 614-1211-0543-22 |                |       |
| 170 | 22743 | SWARNALI DAS        | 222614-12-0170 | 614-1211-0544-22 | Swarnali Das   |       |
| 171 | 22606 | RIMPA MAITY         | 222614-12-0171 | 614-1211-0545-22 |                |       |
| 172 | 22637 | RUPSHA PAL          | 222614-12-0172 | 614-1211-0547-22 | Rupsha Pal     |       |
| 173 | 22655 | SALAHA KHATOON      | 222614-12-0173 | 614-1211-0548-22 | Salaha Khatun  |       |
| 174 | 22626 | RUKSAD KHATUN       | 222614-12-0174 | 614-1211-0549-22 | Ruksad Khatun  |       |
| 175 | 22591 | PUNAM KUMARI PRASAD | 222614-12-0175 | 614-1211-0550-22 |                |       |
| 176 | 22629 | RUKSHA KHATUN       | 222614-12-0176 | 614-1211-0551-22 | Ruksha Khatun  |       |
| 177 | 22661 | SAMPA DAS           | 222614-12-0177 | 614-1211-0554-22 | Sampa Das      |       |
| 178 | 22502 | KOYEL POREL         | 222614-12-0178 | 614-1211-0555-22 | Koyel Porel    |       |
| 179 | 22476 | ISHNEHA SHAW        | 222614-12-0179 | 614-1211-0556-22 | Ishneha Shaw   |       |
| 180 | 22686 | SHIPRA KHANRA       | 222614-12-0180 | 614-1211-0557-22 | Shipra Khanra  |       |
| 181 | 22533 | NAFISA PARVEEN      | 222614-12-0181 | 614-1211-0558-22 | Nafisa Parveen |       |
| 182 | 22715 | SOMASHREE DAS       | 222614-12-0182 | 614-1211-0560-22 | Somashree Das  |       |
| 183 | 22732 | SUNAMI DEY          | 222614-12-0183 | 614-1211-0563-22 | Sunami Dey     |       |
| 184 | 22475 | ISHITA KUMARI       | 222614-12-0184 | 614-1211-0564-22 | Ishita Kumari  |       |
| 185 | 22757 | TIASA SANTRA        | 222614-12-0185 | 614-1211-0565-22 | Tiasa Santra   |       |
| 186 | 22659 | SAMAPTI BAUL        | 222614-12-0186 | 614-1211-0566-22 | Samapti Baul   |       |
| 187 | 22498 | KHURSIDA KHATUN     | 222614-12-0187 | 614-1211-0567-22 |                |       |
| 188 | 22405 | AMINA KHATUN        | 222614-12-0188 | 614-1211-0568-22 |                |       |
| 189 | 22751 | TANIMA KOLEY        | 222614-12-0189 | 614-1211-0570-22 | Tanima Koley   |       |
| 190 | 22427 | ARPITA BISWAS       | 222614-12-0190 | 614-1211-0572-22 | Arpita Biswas  |       |

Soma Roy,  
Principal  
Serampore Girls' College  
Serampore, Hooghly

## ENVS project submission : 2nd sem BA BSC General 2023

| Sl  | Roll  | Name                 | CU Roll        | CU Reg           | Signature         | Marks |
|-----|-------|----------------------|----------------|------------------|-------------------|-------|
| 191 | 22738 | SUSHMA TIWARI        | 222614-12-0191 | 614-1211-0573-22 |                   |       |
| 192 | 22566 | PIYASA NANDI         | 222614-12-0192 | 614-1211-0576-22 | Piyasa Nandi      |       |
| 193 | 22450 | BINITA SAHA          | 222614-12-0193 | 614-1211-0577-22 | Binita Saha.      |       |
| 194 | 22767 | UJALA KUMARI YADAV   | 222614-12-0194 | 614-1211-0578-22 | Ujala Yadav       |       |
| 195 | 22439 | AYANTIKA SAHA        | 222614-12-0195 | 614-1211-0579-22 |                   |       |
| 196 | 22444 | BARSHA DAS           | 222614-12-0196 | 614-1211-0580-22 | Barsha Das        |       |
| 197 | 22583 | PRIYANKA BARMAN      | 222614-12-0197 | 614-1211-0581-22 | Priyanka Barman   |       |
| 198 | 22558 | PAYEL CHAKRABORTY    | 222614-12-0198 | 614-1211-0582-22 | Payel Chakraborty |       |
| 199 | 22553 | NOSIN NASIM          | 222614-12-0199 | 614-1211-0583-22 | Nosin Nasim       |       |
| 200 | 22624 | RUCHI SINGH          | 222614-12-0200 | 614-1211-0584-22 |                   |       |
| 201 | 22510 | MAMATA PARIDA        | 222614-12-0201 | 614-1211-0585-22 | Mamata Parida     |       |
| 202 | 22492 | KEYA BHOWMICK        | 222614-12-0202 | 614-1211-0586-22 | Keya Bhowmick     |       |
| 203 | 22704 | SNEHA DAS            | 222614-12-0203 | 614-1211-0587-22 | Sneha Das         |       |
| 204 | 22628 | RUKSAR KHATUN        | 222614-12-0204 | 614-1211-0588-22 |                   |       |
| 205 | 22679 | SHABNAM BHATTACHARYA | 222614-12-0205 | 614-1211-0591-22 |                   |       |
| 206 | 22454 | DELESHWARY SHAW      | 222614-12-0206 | 614-1211-0592-22 | Deleshwary Shaw   |       |
| 207 | 22581 | PRIYA SANTRA         | 222614-12-0207 | 614-1211-0593-22 |                   |       |
| 208 | 22435 | ASHMITA SOM          | 222614-12-0208 | 614-1211-0594-22 | Ashmita Som       |       |
| 209 | 22647 | SAGUFTA PARVEEN      | 222614-12-0209 | 614-1211-0595-22 |                   |       |
| 210 | 22491 | KAVITA SHARMA        | 222614-12-0210 | 614-1211-0596-22 |                   |       |
| 211 | 22744 | SWEETY KUMARI        | 222614-12-0211 | 614-1211-0597-22 | Sweety Kumari     |       |
| 212 | 22432 | ARUNIMA CHANDRA      | 222614-12-0212 | 614-1211-0598-22 | Arunima Chandra   |       |
| 213 | 22598 | RANI SHARMA          | 222614-12-0213 | 614-1211-0599-22 |                   |       |
| 214 | 22536 | NASRIN KHATUN        | 222614-12-0214 | 614-1211-0601-22 |                   |       |
| 215 | 22472 | IPSITA DAS           | 222614-12-0215 | 614-1211-0602-22 |                   |       |
| 216 | 22660 | SAMMA KHATUN         | 222614-12-0216 | 614-1211-0603-22 | Samma Khatun      |       |
| 217 | 22724 | SUJATA BHASKAR       | 222614-12-0217 | 614-1211-0605-22 | Sujata Bhaskar    |       |
| 218 | 22459 | DIPTI RAY            | 222614-12-0218 | 614-1211-0608-22 | Dipti Ray         |       |
| 219 | 22574 | PRITI SHA            | 222614-12-0219 | 614-1211-0609-22 | Priti Sha         |       |
| 220 | 22741 | SWAGATA ADDYA        | 222614-12-0220 | 614-1211-0610-22 |                   |       |
| 221 | 22755 | TASLIMA KHATUN       | 222614-12-0221 | 614-1211-0613-22 | Taslima Khatun    |       |
| 222 | 22549 | NILUFA KHATUN        | 222614-12-0222 | 614-1211-0614-22 | Nilufa Khatun     |       |
| 223 | 22653 | SAIYEDA KHATUN       | 222614-12-0223 | 614-1211-0615-22 | Saiyeda Khatun    |       |
| 224 | 22657 | SALMA KHATUN         | 222614-12-0224 | 614-1211-0616-22 | Salma Khatun      |       |
| 225 | 22739 | SUSMITA GHOSH        | 222614-12-0225 | 614-1211-0617-22 | Susmita Ghosh     |       |
| 226 | 22563 | PIU DAS              | 222614-12-0226 | 614-1211-0618-22 | Piu Das.          |       |
| 227 | 22499 | KOYEL DAS            | 222614-12-0227 | 614-1211-0619-22 |                   |       |
| 228 | 22714 | SOMA DAS             | 222614-12-0228 | 614-1211-0620-22 | Soma Das          |       |

## ENVS project submission : 2nd sem BA BSC General 2023

| Roll | Name                                | CU Roll                   | CU Reg                      | Signature           | Marks |
|------|-------------------------------------|---------------------------|-----------------------------|---------------------|-------|
| 229  | 22547 NIDHI GUPTA                   | 222614-12-0229            | 614-1211-0622-22            | Nidhi Gupta         |       |
| 230  | 22564 PIU KOLEY                     | 222614-12-0230            | 614-1211-0623-22            | Piu Koley           |       |
| 231  | 22600 RANJANA SHAW                  | 222614-12-0231            | 614-1211-0625-22            | Ranjana Shaw        |       |
| 232  | 22638 RUQAIYA KHATOON               | 222614-12-0232            | 614-1211-0626-22            | Ruqaiya Khatoon     |       |
| 233  | 22698 SIMRAN PRASAD                 | 222614-12-0233            | 614-1211-0627-22            | Simran Prasad       |       |
| 234  | 22672 SANJU KUMARI YADAV            | 222614-12-0234            | 614-1211-0628-22            | Sanju Kumari Yadav  |       |
| 235  | 22642 SABITA KUMARI YADAV           | 222614-12-0235            | 614-1211-0629-22            | Sabita Kumari Yadav |       |
| 236  | <del>22604 RIMA KHATOON</del>       | <del>222614-12-0236</del> | <del>614-1211-0630-22</del> |                     |       |
| 237  | 22543 NEHA KUMARI YADAV             | 222614-12-0237            | 614-1211-0636-22            | Neha Kumari Yadav   |       |
| 238  | 22702 SNEHA BARMAN                  | 222614-12-0238            | 614-1211-0637-22            | Sneha Barman        |       |
| 239  | <del>22681 SHAHINA BANO</del>       | <del>222614-12-0239</del> | <del>614-1211-0639-22</del> |                     |       |
| 240  | 22484 JYOTI KUMARI CHOURASIA        | 222614-12-0240            | 614-1211-0641-22            |                     |       |
| 241  | <del>22555 PANKAJINI BARIK</del>    | <del>222614-12-0241</del> | <del>614-1211-0642-22</del> |                     |       |
| 242  | <del>22636 RUPSHA DAS</del>         | <del>222614-12-0242</del> | <del>614-1211-0644-22</del> |                     |       |
| 243  | 22666 SANGITA BAG                   | 222614-12-0243            | 614-1211-0645-22            |                     |       |
| 244  | 22720 SREEJEETA MUKHERJEE           | 222614-12-0244            | 614-1211-0646-22            | Sreejeeta Mukherjee |       |
| 245  | 22762 TRIYASHA DEY                  | 222614-12-0245            | 614-1211-0647-22            |                     |       |
| 246  | 22585 PRONOTI PAL                   | 222614-12-0246            | 614-1211-0648-22            | Pronoti Pal         |       |
| 247  | 22425 ARCHANA SINGH                 | 222614-12-0247            | 614-1211-0649-22            | Archana Singh       |       |
| 248  | 22541 NEHA JAISWAL                  | 222614-12-0248            | 614-1211-0654-22            | Neha Jaiswal        |       |
| 249  | 22683 SHAMA KHATOON                 | 222614-12-0249            | 614-1211-0657-22            |                     |       |
| 250  | 22552 NOOR SABA                     | 222614-12-0250            | 614-1211-0659-22            |                     |       |
| 251  | 22756 TASNIMA ARA                   | 222614-12-0251            | 614-1211-0660-22            | Tasnima Ara         |       |
| 252  | 22528 MOUSUMI DEY                   | 222614-12-0252            | 614-1211-0661-22            | Mousumi Dey         |       |
| 253  | 22453 DEBIKA BHANDARI               | 222614-12-0253            | 614-1211-0666-22            |                     |       |
| 254  | <del>22635 RUPSHA KANGSABANIK</del> | <del>222614-12-0254</del> | <del>614-1211-0667-22</del> |                     |       |
| 255  | 22800 RESHMA KHATOON                | 222614-12-0255            | 614-1211-0674-22            | Reshma Khatoon      |       |
| 256  | 22799 ANCHAL KUMARI OJHA            | 222614-12-0256            | 614-1211-0675-22            | Anchal K. Ojha      |       |
| 257  | 22802 RUBY KUMARI JHA               | 222614-12-0257            | 614-1211-0676-22            | Ruby Kumari Jha     |       |
| 258  | 22593 PURBASHA NASKAR               | 222614-12-0258            | 614-1212-0315-22            | Purbasha Naskar     |       |
| 259  | 22587 PUJA BHUIMALI                 | 222614-12-0259            | 614-1212-0316-22            | Puja Bhumali        |       |
| 260  | 22737 SUSHMA MONDAL                 | 222614-12-0260            | 614-1212-0323-22            | Sushma Mondal       |       |
| 261  | 22429 ARPITA MALIK                  | 222614-12-0261            | 614-1212-0339-22            | Arpita Malik        |       |
| 262  | 22734 SUPRITI HALDAR                | 222614-12-0262            | 614-1212-0343-22            | Supriti Haldar      |       |
| 263  | 22710 SNIGDHA KARAK                 | 222614-12-0263            | 614-1212-0347-22            | Snigdha Karak       |       |
| 264  | 22482 JUHI CHOUDHARY                | 222614-12-0264            | 614-1212-0351-22            | Juhi Choudhary      |       |
| 265  | 22701 SNEHA BAG                     | 222614-12-0265            | 614-1212-0360-22            | Sneha Bag           |       |
| 266  | 22618 RIYA MALIK                    | 222614-12-0266            | 614-1212-0370-22            |                     |       |

## ENVS project submission : 2nd sem BA BSC General 2023

| Roll | Name  | CU Roll             | CU Reg         | Signature        | Marks               |
|------|-------|---------------------|----------------|------------------|---------------------|
| 267  | 22458 | DIPTI MALIK         | 222614-12-0267 | 614-1212-0375-22 |                     |
| 268  | 22752 | TANIYA BAG          | 222614-12-0268 | 614-1212-0399-22 | Taniya Bag          |
| 269  | 22761 | TIYASA NASKAR       | 222614-12-0269 | 614-1212-0406-22 | Tiyasa Naskar       |
| 270  | 22692 | SHREYA PATRA        | 222614-12-0270 | 614-1212-0415-22 | Shreya Patra        |
| 271  | 22769 | URMILA BHUIYA       | 222614-12-0271 | 614-1212-0422-22 | Urmila Bhuiya       |
| 272  | 22699 | SIYA BISWAS         | 222614-12-0272 | 614-1212-0462-22 |                     |
| 273  | 22529 | MOUSUMI SARKAR      | 222614-12-0273 | 614-1212-0463-22 |                     |
| 274  | 22504 | LEENA BAG           | 222614-12-0274 | 614-1212-0466-22 | Leena Bag           |
| 275  | 22745 | SWEETY MAJHI        | 222614-12-0275 | 614-1212-0471-22 | Sweety Majhi        |
| 276  | 22430 | ARPITA MONDAL       | 222614-12-0276 | 614-1212-0472-22 | Arpita Mondal       |
| 277  | 22588 | PUJA DHAKI          | 222614-12-0277 | 614-1212-0484-22 | Puja Dhaki          |
| 278  | 22690 | SHREYA KHAN         | 222614-12-0278 | 614-1212-0485-22 | Shreya Khan         |
| 279  | 22763 | TRİYASHA ROY        | 222614-12-0279 | 614-1212-0520-22 | Triyasha Roy        |
| 280  | 22716 | SOUJANYA KAYAL      | 222614-12-0280 | 614-1212-0522-22 | Soujanya Kayal      |
| 281  | 22586 | PUJA PATRA          | 222614-12-0281 | 614-1212-0526-22 | Puja Patra          |
| 282  | 22486 | KAJAL RAJ MAJHI     | 222614-12-0282 | 614-1212-0532-22 | Kajal Raj Majhi     |
| 283  | 22671 | SANJITA BRAHMA      | 222614-12-0283 | 614-1212-0534-22 | Sanjita Brahma      |
| 284  | 22506 | LIPIKA MAJHI        | 222614-12-0284 | 614-1212-0541-22 | Lipika Majhi        |
| 285  | 22730 | SUMITA GHORUI       | 222614-12-0285 | 614-1212-0546-22 | Sumita Ghorui       |
| 286  | 22438 | AVANTIKA BISWAL;    | 222614-12-0286 | 614-1212-0552-22 | Avantika Biswal     |
| 287  | 22419 | ANURIA BISWAS       | 222614-12-0287 | 614-1212-0562-22 | Anuria Biswas       |
| 288  | 22742 | SWAPNA MALIK        | 222614-12-0288 | 614-1212-0569-22 |                     |
| 289  | 22559 | PAYEL PAIK          | 222614-12-0289 | 614-1212-0574-22 |                     |
| 290  | 22422 | ANWESHA HOWLADAR    | 222614-12-0290 | 614-1212-0575-22 | Anwisha Howladar    |
| 291  | 22610 | RITIKA DHARA        | 222614-12-0291 | 614-1212-0589-22 | Ritika Dhara        |
| 292  | 22511 | MANASI SANTRA       | 222614-12-0292 | 614-1212-0612-22 | Manasi Santra       |
| 293  | 22597 | RAKHI KUMARI PRASAD | 222614-12-0293 | 614-1212-0621-22 | Rakhi Kumari Prasad |
| 294  | 22413 | ANKITA MONDAL       | 222614-12-0294 | 614-1212-0650-22 | Ankita Mondal       |
| 295  | 22479 | JAYA MAL            | 222614-12-0295 | 614-1212-0651-22 | Jaya mal.           |
| 296  | 22410 | ANINDITA DAS        | 222614-12-0296 | 614-1212-0652-22 | Anindita Das        |
| 297  | 22617 | RIYA KARAK          | 222614-12-0297 | 614-1212-0658-22 |                     |
| 298  | 22669 | SANJANA MALIK       | 222614-12-0298 | 614-1212-0665-22 | Sanjana Malik       |
| 299  | 22577 | PRIYA BAG           | 222614-12-0299 | 614-1212-0668-22 | Priya Bag.          |
| 300  | 22797 | SANCHITA HAZRA      | 222614-12-0300 | 614-1212-0672-22 |                     |
| 301  | 22676 | SATHI KAL           | 222614-12-0301 | 614-1213-0479-22 | Sathi Kal           |
| 302  | 22561 | PAYEL SHAW          | 222614-12-0302 | 614-1214-0322-22 | Payel Shaw.         |
| 303  | 22554 | PALLABI GHOSH       | 222614-12-0303 | 614-1214-0335-22 | Pallabi Ghosh.      |
| 304  | 22733 | SUPRITI GHOSH       | 222614-12-0304 | 614-1214-0342-22 | Supriti Ghosh       |

ENVS project submission : 2nd sem BA BSC General 2023

| Roll | Name                           | CU Roll        | CU Reg           | Signature              | Marks |
|------|--------------------------------|----------------|------------------|------------------------|-------|
| 305  | 22440 AYASA KHATUN             | 222614-12-0305 | 614-1214-0344-22 | Ayasa Khatun           |       |
| 306  | 22578 PRIYA DHOLEY             | 222614-12-0306 | 614-1214-0350-22 | Priya Dholey           |       |
| 307  | 22481 JHUMA PAUL               | 222614-12-0307 | 614-1214-0354-22 | Jhuma Paul             |       |
| 308  | 22474 ISHITA DAS               | 222614-12-0308 | 614-1214-0366-22 | Ishita Das             |       |
| 309  | 22576 PRITI SHAW               | 222614-12-0309 | 614-1214-0417-22 | Priti Shaw             |       |
| 310  | 22721 SREYA PAL                | 222614-12-0310 | 614-1214-0435-22 | Sreya Pal.             |       |
| 311  | 22663 SANCHITA KARMAKAR        | 222614-12-0311 | 614-1214-0437-22 | Sanchita Karmakar      |       |
| 312  | 22719 SRABANI KARMAKAR         | 222614-12-0312 | 614-1214-0447-22 | Srabani Karmakar       |       |
| 313  | 22501 KOYEL PAL                | 222614-12-0313 | 614-1214-0457-22 | Koyel Pal              |       |
| 314  | 22565 PIUPA MODAK              | 222614-12-0314 | 614-1214-0488-22 | Piupa Modak            |       |
| 315  | 22530 MUSKAN KHATOON           | 222614-12-0315 | 614-1214-0495-22 | Muskan Khatun          |       |
| 316  | 22630 RUMI PAL                 | 222614-12-0316 | 614-1214-0514-22 | Rumi Pal.              |       |
| 317  | 22443 BARNALI GHOSH            | 222614-12-0317 | 614-1214-0516-22 | Barnali Ghosh          |       |
| 318  | 22508 MALABIKA NARU            | 222614-12-0318 | 614-1214-0540-22 | Malabika Naru          |       |
| 319  | 22722 SUCHETANA GHOSH          | 222614-12-0319 | 614-1214-0561-22 | Suchetana Ghosh        |       |
| 320  | 22460 DISHA GHOSH              | 222614-12-0320 | 614-1214-0571-22 | Disha Ghosh            |       |
| 321  | 22434 ASHMA KHATOON            | 222614-12-0321 | 614-1214-0606-22 | Ashma Khatun           |       |
| 322  | 22594 PURBASHA PAUL            | 222614-12-0322 | 614-1214-0638-22 | Purbasha Paul          |       |
| 323  | 22670 SANJANA PAL              | 222614-12-0323 | 614-1214-0662-22 | Sanjana Pal            |       |
| 324  | 22801 KASHIBA PARVEEN          | 222614-12-0324 | 614-1214-0671-22 | Kashiba Parveen        |       |
| 325  | 22804 NAINA GUPTA              | 222614-12-0325 | 614-1214-0673-22 | Naina Gupta            |       |
| 326  | 22668 SANIA KHATUN             | 222614-12-0326 | 614-1215-0329-22 | Sania Khatun           |       |
| 327  | 22468 FARZANA KHATOON          | 222614-12-0327 | 614-1215-0331-22 | Farzana Khatun         |       |
| 328  | 22622 ROOKSANA KHATUN          | 222614-12-0328 | 614-1215-0333-22 | Rooksana Khatun        |       |
| 329  | 22480 JEBA SOBHAN KHATUN       | 222614-12-0329 | 614-1215-0336-22 | Jeba Sobhan Khatun     |       |
| 330  | 22471 HASIFA KHATUN            | 222614-12-0330 | 614-1215-0340-22 | Hasifa Khatun          |       |
| 331  | 22621 RONGINA KHATUN           | 222614-12-0331 | 614-1215-0341-22 | Rongina Khatun         |       |
| 332  | 22477 ISRAT PARVEEN            | 222614-12-0332 | 614-1215-0355-22 | Israt Parveen          |       |
| 333  | 22404 ALISA PARVEEN            | 222614-12-0333 | 614-1215-0379-22 | Alisa Parveen          |       |
| 334  | 22465 FARHANA KHATUN           | 222614-12-0334 | 614-1215-0403-22 | Farhana Khatun         |       |
| 335  | 22750 TAMANNA TABASSUM KHATOON | 222614-12-0335 | 614-1215-0408-22 | Tamanna Khatun         |       |
| 336  | 22652 SAISHTA TABASSUM         | 222614-12-0336 | 614-1215-0409-22 | Saishta Tabassum       |       |
| 337  | 22452 DARAKHSHAN NOORIE        | 222614-12-0337 | 614-1215-0419-22 | Darakhshan Noorie      |       |
| 338  | 22483 JULFA KHATUN             | 222614-12-0338 | 614-1215-0425-22 | Julfakhatun            |       |
| 339  | 22485 KAHKASHA PARVEEN         | 222614-12-0339 | 614-1215-0431-22 | Kahkasha Parveen       |       |
| 340  | 22518 MOSAMMAD SAHINA KHATUN   | 222614-12-0340 | 614-1215-0509-22 | Mosammad Sahina Khatun |       |
| 341  | 22765 TUHINA PARVIN            | 222614-12-0341 | 614-1215-0512-22 | Tuhina Parvin          |       |
| 342  | 22697 SIMRAN KHATUN            | 222614-12-0342 | 614-1215-0531-22 | Simran Khatun          |       |

## ENVS project submission : 2nd sem BA BSC General 2023

| Roll | Name                     | CU Roll        | CU Reg           | Signature         | Marks |
|------|--------------------------|----------------|------------------|-------------------|-------|
| 343  | 22538 NEGAR PARVEEN      | 222614-12-0343 | 614-1215-0535-22 | Negar Parveen     |       |
| 344  | 22537 NAZRA PARVEEN      | 222614-12-0344 | 614-1215-0553-22 |                   |       |
| 345  | 22678 SHABA NAZ          | 222614-12-0345 | 614-1215-0559-22 | Shaba Naz         |       |
| 346  | 22516 MOHOTARA YASMIN    | 222614-12-0346 | 614-1215-0590-22 |                   |       |
| 347  | 22464 FAREEN GULSHAN     | 222614-12-0347 | 614-1215-0600-22 |                   |       |
| 348  | 22462 ESMAT PARVEEN      | 222614-12-0348 | 614-1215-0604-22 | Esma Parveen      |       |
| 349  | 22654 SAJDA KHATOON      | 222614-12-0349 | 614-1215-0607-22 | Sajda Khatoon     |       |
| 350  | 22544 NEHA PARVEEN       | 222614-12-0350 | 614-1215-0611-22 | Meha Parveen      |       |
| 351  | 22400 AFRIN KHATUN       | 222614-12-0351 | 614-1215-0624-22 | Afrin Khatun      |       |
| 352  | 22680 SHAHIN PARVEEN     | 222614-12-0352 | 614-1215-0631-22 |                   |       |
| 353  | 22643 SABIYA KHATOON     | 222614-12-0353 | 614-1215-0632-22 | Sabiya Khatoon    |       |
| 354  | 22696 SIMA KHATOON       | 222614-12-0354 | 614-1215-0633-22 | Simma Khatoon     |       |
| 355  | 22640 SABANA PARWEEN     | 222614-12-0355 | 614-1215-0634-22 | Sabana Parween    |       |
| 356  | 22466 FARIDA KHATOON     | 222614-12-0356 | 614-1215-0635-22 | Farida Khatoon    |       |
| 357  | 22496 KHAHCASHA PARVEEN  | 222614-12-0357 | 614-1215-0640-22 | Khahcashu Parveen |       |
| 358  | 22535 NASRIN KHATOON     | 222614-12-0358 | 614-1215-0643-22 | Nasrin Khatoon    |       |
| 359  | 22639 SABA FIRDOUS       | 222614-12-0359 | 614-1215-0653-22 | Saba Firdous      |       |
| 360  | 22623 ROSHAN PARVEEN     | 222614-12-0360 | 614-1215-0655-22 | Roshan Parveen    |       |
| 361  | 22662 SANA SOUFIA        | 222614-12-0361 | 614-1215-0656-22 | Sana Soufia       |       |
| 362  | 22625 RUKHSAR            | 222614-12-0362 | 614-1215-0663-22 |                   |       |
| 363  | 22531 MUSKAN KHATOON     | 222614-12-0363 | 614-1215-0664-22 | Muskan Khatoon    |       |
| 364  | 22470 HASIBA KHATUN      | 222614-12-0364 | 614-1215-0669-22 |                   |       |
| 365  | 22682 SHAJIYA PARVEEN    | 222614-12-0365 | 614-1215-0670-22 | Shajiya Parveen   |       |
| 366  | 22691 SHREYA KUMARI      | 222614-12-0366 | 614-1211-0701-22 | Shreya Kumari     |       |
| 367  | 22791 SOUMOLI PARUI      | 223614-12-0001 | 614-1211-0677-22 |                   |       |
| 368  | 22786 SAKSHI YADAV       | 223614-12-0002 | 614-1211-0678-22 | Sakshi Yadav      |       |
| 369  | 22790 SHRUTI KUMARI      | 223614-12-0003 | 614-1211-0679-22 | Shruti Kumari     |       |
| 370  | 22787 SANJANA SARKAR     | 223614-12-0004 | 614-1211-0680-22 | Sanjana Sarkar    |       |
| 371  | 22789 SHERINA ALI MONDAL | 223614-12-0005 | 614-1211-0681-22 |                   |       |
| 372  | 22795 SWARNALI PAL       | 223614-12-0006 | 614-1211-0682-22 |                   |       |
| 373  | 22779 PALLABI DAS        | 223614-12-0007 | 614-1211-0683-22 | Pallabi Das       |       |
| 374  | 22788 SATHI MITRA        | 223614-12-0008 | 614-1211-0685-22 | Sathi Mitra       |       |
| 375  | 22780 PIYASA KOLEY       | 223614-12-0009 | 614-1211-0686-22 |                   |       |
| 376  | 22771 ARPITA DEBNATH     | 223614-12-0010 | 614-1211-0687-22 | Arpita Debnath    |       |
| 377  | 22770 ANKITA MONDAL      | 223614-12-0011 | 614-1211-0688-22 | Ankita Mondal     |       |
| 378  | 22776 KOMMANA PAVITRA    | 223614-12-0012 | 614-1211-0689-22 | Kommana Pavitra   |       |
| 379  | 22773 GUNGUN MISHRA      | 223614-12-0013 | 614-1211-0690-22 | Gungun Mishra     |       |
| 380  | 22782 PUJA SHEE          | 223614-12-0014 | 614-1211-0691-22 | Puja Shee         |       |

## ENVS project submission : 2nd sem BA BSC General 2023

| Roll | Name                   | CU Roll        | CU Reg           | Signature        | Marks |
|------|------------------------|----------------|------------------|------------------|-------|
| 381  | 22777 KOYAL BARIK      | 223614-12-0015 | 614-1211-0692-22 | Koyal Barik.     |       |
| 382  | 22794 SUPRIYA DEYASE   | 223614-12-0016 | 614-1211-0693-22 |                  |       |
| 383  | 22774 ISHA SHAW        | 223614-12-0017 | 614-1211-0696-22 | Isha Shaw        |       |
| 384  | 22778 NEHA SINGH       | 223614-12-0018 | 614-1211-0698-22 | Neha Singh       |       |
| 385  | 22775 KEYA RUIDAS      | 223614-12-0019 | 614-1212-0695-22 | Keya Ruidas      |       |
| 386  | 22793 SUDIPTA DEBNATH  | 223614-12-0020 | 614-1214-0684-22 |                  |       |
| 387  | 22781 PRAPTI DAS       | 223614-12-0021 | 614-1214-0694-22 | Prapti Das.      |       |
| 388  | 22796 TITAS GHOSH      | 223614-12-0022 | 614-1214-0697-22 |                  |       |
| 389  | 22772 DISHA GHOSH      | 223614-12-0023 | 614-1214-0699-22 |                  |       |
| 390  | 22792 SUBHRA SADHUKHAN | 223614-12-0024 | 614-1214-0700-22 | Subhra Sadhukhan |       |

| <u>Name</u>       | <u>CU Roll No.</u> | <u>CU Reg. No</u> | <u>Signature</u>  |
|-------------------|--------------------|-------------------|-------------------|
| Lipika Sozen.     | 213614-12-0022     | 614-1211-0748-21  | Lipika Sozen.     |
| Pargel Dey        | 212614-12-0130     | 614-1211-0584-21  | Pargel Dey        |
| Tanusree Banerjee | 212614-12-0059     | 614-1211-0447-21  | Tanusree Banerjee |
| Moumita Roy       | 212614-12-0270     | 614-1212-0582-21  | Moumita Roy       |
| Mampi Das         | 212614-12-0221     | 614-1211-0717-2   | Mampi Das         |
| Mamsi Shaw        | 213614-12-0029     | 614-1211-0757-21  | Mamsi Shaw        |
| Kasurra Das       | 213614-12-0024     | 614-1211-0752-21  | Kasurra Das       |
| Laboni Roy        | 212614-12-0260     | 614-1212-0530-21  | Laboni Roy        |

| Roll No.         | Reg No.          | Name             | Signature     |
|------------------|------------------|------------------|---------------|
| <del>21606</del> | 614-1211-0494-21 | <del>Rupsa</del> |               |
| 212614-12-0078   |                  | Rupsa Majhi      | Rupsa Majhi   |
| 212614-12-0079   | 614-1211-0496-21 | Aarpita Dhank    | Aarpita Dhank |

Soma Roy.  
Principal  
Serampore Girls' College  
Serampore, Hoopla

Project work/field work/ internships  
Name of Course: ENVIRONMENTAL STUDIES  
Code: AECC 2 (honours)  
Course: Environmental Science  
2022-2023

## Criteria 1.3.2



## Serampore Girls College

13, T.C. Goswami Street,  
Serampore, Hooghly – 712201, West Bengal  
Re- Accredited by NAAC : Grade B (2nd Cycle)  
Email: [serampore\\_girls\\_college@yahoo.co.in](mailto:serampore_girls_college@yahoo.co.in)  
Website: [www.seramporegirlscollege.org](http://www.seramporegirlscollege.org)

# Serampore Girls' College

13, T.C. Goswami Street Serampore Hooghly - 712201 West Bengal

## NAAC Criteria 1.3.2



## PROJECT WORK REPORT 2022-2023

### REPORT ON PROJECT WORK OF ENVIRONMENTAL STUDIES (AECC 2)

Academic Session: 2022-2023

SEMESTER:II ( Hons)

**Name of Course:** ENVIRONMENTAL STUDIES

**Code:** AECC 2

**Location:** Serampore Girls' College, WEST BENGAL

#### **Course Objective:**

Students will learn about

- Urban Pollution
- Pond Ecosystem
- River Ecosystem
- Forest ecosystem
- Common birds in your localities

**Date of report submission:** 23/06/2023 and 24/06/2023

**Duration:** 6 months ( 1 semester)

**students enrolled:** 390

**Student submitted:** 390

#### **Guided by:**

Dr. Asrafal Alam ( Department of Geography, Serampore Girls' College)

Priyanaka Dey ( Department of Geography, Serampore Girls' College)

#### **Course Outcome:**

Students were able to learn about Urban Pollution

- Pond Ecosystem
- River Ecosystem
- Forest ecosystem
- Common birds in your localities

*Soma Roy.*  
Principal  
Serampore Girls' College  
Serampore, Hooghly

Signature of Principal

# SYLLABUS OF THE COURSE



## UNIVERSITY OF CALCUTTA

### Notification No. CSR/ 12 /18

It is notified for information of all concerned that the Syndicate in its meeting held on 28.05.2018 (vide Item No.14) approved the Syllabi of different subjects in Undergraduate Honours / General / Major courses of studies (CBCS) under this University, as laid down in the accompanying pamphlet:

#### List of the subjects

| <u>Sl. No.</u> | <u>Subject</u>  | <u>Sl. No.</u> | <u>Subject</u>   |
|----------------|---|----------------|--|
| 1              | Anthropology (Honours / General)                      | 29             | Mathematics (Honours / General)                                |
| 2              | Arabic (Honours / General)                            | 30             | Microbiology (Honours / General)                               |
| 3              | Persian (Honours / General)                           | 31             | Mol. Biology (General)   |
| 4              | Bengali (Honours / General /LCC2 /AECC1)              | 32             | Philosophy (Honours / General)                                 |
| 5              | Bio-Chemistry (Honours / General)                     | 33             | Physical Education (General)                                   |
| 6              | Botany (Honours / General)                            | 34             | Physics (Honours / General)                                    |
| 7              | Chemistry (Honours / General)                         | 35             | Physiology (Honours / General)                                 |
| 8              | Computer Science (Honours / General)                  | 36             | Political Science (Honours / General)                          |
| 9              | Defence Studies (General)                             | 37             | Psychology (Honours / General)                                 |
| 10             | Economics (Honours / General)                         | 38             | Sanskrit (Honours / General)                                   |
| 11             | Education (Honours / General)                         | 39             | Social Science (General)                                       |
| 12             | Electronics (Honours / General)                       | 40             | Sociology (Honours / General)                                  |
| 13             | English ((Honours / General/ LCC1/ LCC2/AECC1)        | 41             | Statistics (Honours / General)                                 |
| 14             | Environmental Science (Honours / General)             | 42             | Urdu (Honours / General /LCC2 /AECC1)                          |
| 15             | Environmental Studies (AECC2)                         | 43             | Women Studies (General)  |
| 16             | Film Studies ( General)                               | 44             | Zoology (Honours / General)                                    |
| 17             | Food Nutrition (Honours / General)                    | 45             | Industrial Fish and Fisheries – IFFV (Major)                   |
| 18             | French (General)                                      | 46             | Sericulture – SRTV (Major)                                     |
| 19             | Geography (Honours / General)                         | 47             | Computer Applications – CMAV (Major)                           |
| 20             | Geology (Honours / General)                           | 48             | Tourism and Travel Management – TTMV (Major)                   |
| 21             | Hindi (Honours / General /LCC2 /AECC1)                | 49             | Advertising Sales Promotion and Sales Management –ASPV (Major) |
| 22             | History (Honours / General)                           | 50             | Communicative English –CMEV (Major)                            |
| 23             | Islamic History Culture (Honours / General)           | 51             | Clinical Nutrition and Dietetics CNDV (Major)                  |
| 24             | Home Science Extension Education (General)            | 52             | Bachelor of Business Administration (BBA) (Honours)            |
| 25             | House Hold Art (General)                              | 53             | Bachelor of Fashion and Apparel Design – (B.F.A.D.) (Honours)  |
| 26             | Human Development (Honours / General)                 | 54             | Bachelor of Fine Art (B.F.A.) (Honours)                        |
| 27             | Human Rights (General)                                | 55             | B. Music (Honours / General) and Music (General)               |
| 28             | Journalism and Mass Communication (Honours / General) |                |  |

The above shall be effective from the academic session 2018-2019.

SENATE HOUSE  
KOLKATA-700073  
The 4<sup>th</sup> June, 2018

Soma Roy.  
Principal  
Serampore Girls' College  
Serampore, Hooghly  
Deputy Registrar

# University of Calcutta

## Under Graduate Curriculum under Choice Based Credit System (CBCS)

### Syllabus for Ability Enhancement Compulsory Course-2 (AECC-2) in Environmental Studies

Semester-2

**Total Marks-100(Credit -2)**

(50 Theory-MCQ type + 30 Project + 10 Internal Assessment + 10 Attendance)

[Marks obtained in this course will be taken to calculate SGPA & CGPA]

#### Theory

|   |            |
|---|------------|
| <b>Unit 1 Introduction to environmental studies</b>   | 2 lectures |
| <ul style="list-style-type: none"><li>•Multidisciplinary nature of environmental studies;</li><li>•Scope and importance; Concept of sustainability and sustainable development.</li></ul>   |            |
| <b>Unit 2 Ecology and Ecosystems</b>  | 6 lectures |
| <ul style="list-style-type: none"><li>•Concept of ecology and ecosystem, Structure and function of ecosystem; Energy flow in an ecosystem; food chains, food webs; Basic concept of population and community ecology; ecological succession.</li><li>•Characteristic features of the following:<ul style="list-style-type: none"><li>a) Forest ecosystem</li><li>b) Grassland ecosystem</li><li>c) Desert ecosystem</li><li>d) Aquatic ecosystems (ponds, streams, lakes, wetlands, rivers, oceans, estuaries)</li></ul></li></ul>  |            |
| <b>Unit 3 Natural Resources</b>   | 8 lectures |
| <ul style="list-style-type: none"><li>• Concept of Renewable and Non-renewable resources</li><li>• Land resources and land use change; Land degradation, soil erosion and desertification.</li><li>•Deforestation: Causes, consequences and remedial measures</li><li>•Water: Use and over-exploitation of surface and ground water, floods, droughts, conflicts over water (international &amp; inter-state).</li><li>•Energy resources: Environmental impacts of energy generation, use of alternative and nonconventional energy sources, growing energy needs.</li></ul>  |            |
| <b>Unit 4 Biodiversity and Conservation</b>   | 8 lectures |
| <ul style="list-style-type: none"><li>•Levels of biological diversity: genetic, species and ecosystem diversity;</li><li>• Biogeographic zones of India; Biodiversity patterns and global biodiversity hot spots</li><li>•India as a mega-biodiversity nation; Endangered and endemic species of India</li><li>•Threats to biodiversity: Habitat loss, poaching of wildlife, man-wildlife conflicts, biological invasions;</li><li>•Conservation of biodiversity: In-situ and Ex-situ conservation of biodiversity.</li><li>•Ecosystem and biodiversity services: Ecological, economic, social, ethical, aesthetic and Informational value.</li></ul> |            |
| <b>Unit 5 Environmental Pollution</b>   | 8 lectures |
| <ul style="list-style-type: none"><li>• Environmental pollution: concepts and types,</li><li>• Air, water, soil, noise and marine pollution- causes, effects and controls</li><li>• Concept of hazardous waste and human health risks</li><li>• Solid waste management: Control measures of Municipal, bic</li></ul>  |            |

Soma Roy.  
Principal  
Serampore Girls' College  
Serampore, Hooghly

|   |                     |
|---|---------------------|
| <b>Unit 6 Environmental Policies and Practices</b>  | 7 lectures          |
| <ul style="list-style-type: none"> <li>•Climate change, global warming, ozone layer depletion, acid rain and their impacts on human communities and agriculture</li> <li>•Environment Laws: Wildlife Protection Act; Forest Conservation Act. Water (Prevention and control of Pollution) Act; Air (Prevention &amp; Control of Pollution) Act; Environment Protection Act; Biodiversity Act.</li> <li>•International agreements: Montreal Protocol, Kyoto protocol and climate negotiations; Convention on Biological Diversity (CBD).</li> <li>•Protected area network, tribal populations and rights, and human wildlife conflicts in Indian context.</li> </ul> |                     |
| <b>Unit 7 Human Communities and the Environment</b>   | 6 lectures          |
| <ul style="list-style-type: none"> <li>•Human population growth: Impacts on environment, human health and welfare.</li> <li>•Case studies on Resettlement and rehabilitation.</li> <li>• Environmental Disaster: Natural Disasters-floods, earthquake, cyclones, tsunami and landslides; Manmade Disaster- Bhopal and Chernobyl.</li> <li>•Environmental movements: Bishnois, Chipko, Silent valley, Big dam movements.</li> <li>•Environmental ethics: Role of gender and cultures in environmental conservation.</li> <li>•Environmental education and public awareness</li> </ul>  |                     |
| <b>Project/ Field work</b>  | Equal to 5 lectures |
| <ul style="list-style-type: none"> <li>•Visit to an area to document environmental assets: Natural resources/flora/fauna, etc.</li> <li>•Visit to a local polluted site-Urban/Rural/Industrial/Agricultural.</li> <li>•Study of common plants, insects, fish, birds, mammals and basic principles of identification.</li> <li>•Study of ecosystems-pond, river, wetland, forest, estuary and agro ecosystem.</li> </ul>   |                     |
| <b>Total</b>  | <b>50 Lectures</b>  |

**Suggested Reading:**

Asthana, D. K. (2006). *Text Book of Environmental Studies*. S. Chand Publishing.

Basu, M., Xavier, S. (2016). *Fundamentals of Environmental Studies*, Cambridge University Press, India

Basu, R. N., (Ed.) (2000). *Environment*. University of Calcutta, Kolkata

Bharucha, E. (2013). *Textbook of Environmental Studies for Undergraduate Courses*. Universities Press.

De, A.K., (2006). *Environmental Chemistry*, 6th Edition, New Age International, New Delhi.

Mahapatra, R., Jeevan, S.S., Das, S. (Eds) (2017). *Environment Reader for Universities*, Centre for Science and Environment, New Delhi.

Masters, G. M., & Ela, W. P. (1991). *Introduction to environmental engineering and science*. Englewood Cliffs, NJ: Prentice Hall.

Odum, E. P., Odum, H. T., & Andrews, J. (1971). *Fundamentals of ecology*. Philadelphia: Saunders.

Sharma, P. D., & Sharma, P. D. (2005). *Ecology and environment*. Rastogi Pu

Soma Roy,  
Principal  
Serampore Girls' College  
Serampore, Hooghly

# NOTICE FOR REPORT SUBMISSION

## Serampore Girls' College

(Affiliated to the University of Calcutta)

### Department of Geography

13, T.C. Goswami Street, Serampore, Hooghly - 712201, West Bengal, India

Email: [sgcgeoofficial@gmail.com](mailto:sgcgeoofficial@gmail.com) (Office) / [asraful@seramporegirlscollege.org](mailto:asraful@seramporegirlscollege.org) (HoD)

Ref. No...[SN/N/24/2023](#)

Date: [17/06/2023](#)

#### Notice

This is to be notified to all semester II Honours students that they are being requested to submit the ENVS Project (As notified before) on 23rd and 24th June, 2023 according to the Schedules, mentioned bellow. Everybody are being requested to bring their university admit card of pervious semester, positively 30 minutes before the schedule time.

#### Submission of ENVS Project with Date & Time

| SL. NO. | Subject           | Date                        | Time                 |
|---------|-------------------|-----------------------------|----------------------|
| 1       | English           | 23 <sup>rd</sup> June, 2023 | 11:30 am to 12:30 pm |
| 2       | Education         | 23 <sup>rd</sup> June, 2023 | 12:30 pm to 1:30 pm  |
| 3       | Sanskrit          | 23 <sup>rd</sup> June, 2023 | 1:30 pm to 2:00 pm   |
| 4       | History           | 23 <sup>rd</sup> June, 2023 | 2:30 pm to 3:00 pm   |
| 5       | Computer Science  | 23 <sup>rd</sup> June, 2023 | 3:00 pm to 3:30 pm   |
| 6       | Bengali           | 24 <sup>th</sup> June, 2023 | 11:00am to 12:00 pm  |
| 7       | Philosophy        | 24 <sup>th</sup> June, 2023 | 12:00 pm to 12:45 pm |
| 8       | Political Science | 24 <sup>th</sup> June, 2023 | 12: 45 pm to 1:30 pm |
| 9       | Geography         | 24 <sup>th</sup> June, 2023 | 1:30 pm to 2:30 pm   |

(Dr. Asraful Alam)

(Ms. Priyanka Dey)

Soma Roy.  
Principal  
Serampore Girls' College  
Serampore, Hooghly

Soma Roy.  
Principal  
Serampore Girls' College  
Serampore, Hooghly

Soma Roy,  
Principal  
Serampore Girls' College  
Serampore, Hooghly

## ATTENDANCE OF STUDENTS DURING REPORT SUBMISSION

### BA BSc Honours : 2nd Semester 2023

#### ENVS Project Submission

| SL | Roll  | Name               | CU Roll        | CU Reg           | Signature          |
|----|-------|--------------------|----------------|------------------|--------------------|
| 1  | 22001 | ALEYA KHATUN       | 222614-11-0266 | 614-1215-0078-22 | Aleya Khatun.      |
| 2  | 22002 | ANANDITA TATWA     | 222614-11-0230 | 614-1214-0090-22 | Anandita Tatwa.    |
| 3  | 22003 | ANISHA MUKHERJEE   | 222614-11-0104 | 614-1211-0172-22 | Anisha mukherjee   |
| 4  | 22004 | ANKITA MAITI       | 222614-11-0085 | 614-1211-0135-22 | Ankita Maiti       |
| 5  | 22005 | ANTINA MUKHERJEE   | 222614-11-0043 | 614-1211-0067-22 | Antina Mukherjee.  |
| 6  | 22006 | ANUSHMITA KARAK    | 222614-11-0109 | 614-1211-0180-22 | Anushmita Karak    |
| 7  | 22007 | APARNA MALIK       | 222614-11-0194 | 614-1212-0137-22 | Aparna Malik       |
| 8  | 22008 | ARUNIMA GHOSH      | 222614-11-0056 | 614-1211-0086-22 | Arunima Ghosh      |
| 9  | 22009 | DEBASHREE SAREN    | 222614-11-0219 | 614-1213-0122-22 | Debashree Saren    |
| 10 | 22010 | DEBI SHARMA        | 222614-11-0029 | 614-1211-0047-22 | Debi Sharma        |
| 11 | 22011 | DEEPTIKA KARMAKAR  | 222614-11-0225 | 614-1214-0028-22 | Deepatika Karmakar |
| 12 | 22012 | HIYA ORAON         | 222614-11-0221 | 614-1213-0197-22 | Hiya Oraon         |
| 13 | 22013 | INDRANI GHOSH      | 222614-11-0015 | 614-1211-0026-22 | Indrani Ghosh      |
| 14 | 22014 | JAYITA SADHUKHAN   | 222614-11-0228 | 614-1214-0065-22 | Jayita Sadhukhan.  |
| 15 | 22015 | JUI SHIL           | 222614-11-0232 | 614-1214-0109-22 | Jui Shil           |
| 16 | 22016 | KOUSANY CHATTERJEE | 222614-11-0093 | 614-1211-0152-22 |                    |
| 17 | 22017 | LAXMI MUDI         | 222614-11-0220 | 614-1213-0158-22 | Laxmi Mudi         |
| 18 | 22018 | LIPIKA DUTTA       | 222614-11-0131 | 614-1211-0215-22 |                    |
| 19 | 22019 | MINAKHI PATRA      | 222614-11-0023 | 614-1211-0038-22 | Minakhi Patra      |
| 20 | 22020 | MONALISA MISTERY   | 222614-11-0211 | 614-1212-0229-22 | Monalisa Mistery   |
| 21 | 22021 | NEHA HARI          | 222614-11-0181 | 614-1212-0061-22 | Neha-Hari          |
| 22 | 22022 | NISHA PAUL         | 222614-11-0018 | 614-1211-0031-22 | Nisha Paul         |
| 23 | 22023 | OYESHREE DHALI     | 222614-11-0198 | 614-1212-0166-22 |                    |
| 24 | 22024 | PAYEL DUTTA        | 222614-11-0022 | 614-1211-0037-22 | Payel Dutta        |
| 25 | 22025 | PRIYA DUTTA        | 222614-11-0092 | 614-1211-0150-22 | Priya Dutta        |
| 26 | 22026 | PRIYANKA PAL       | 222614-11-0074 | 614-1211-0114-22 | Priyanka Pal.      |
| 27 | 22027 | PRIYANKA SAHA      | 222614-11-0063 | 614-1211-0095-22 | Priyanka Saha      |
| 28 | 22028 | RACHANA MANDAL     | 222614-11-0084 | 614-1211-0134-22 | Rachana Mandal     |
| 29 | 22029 | RIMA GHOSH         | 222614-11-0239 | 614-1214-0141-22 | Rigma Ghosh        |
| 30 | 22030 | RIYA DAS           | 222614-11-0040 | 614-1211-0062-22 | Riya Das           |
| 31 | 22031 | RIYA DAS           | 222614-11-0073 | 614-1211-0112-22 | Riya Das           |
| 32 | 22032 | RIYA PAL           | 222614-11-0224 | 614-1214-0010-22 |                    |
| 33 | 22033 | RUPSHA MAN         | 222614-11-0191 | 614-1212-0113-22 |                    |

Soma Roy,  
Principal  
Serampore Girls' College  
Serampore, Hoopla

## BA BSc Honours : 2nd Semester 2023

### ENVS Project Submission

| SL | Roll  | Name                 | CU Roll        | CU Reg           | Signature             |
|----|-------|----------------------|----------------|------------------|-----------------------|
| 34 | 22034 | SAMATA DEY           | 222614-11-0115 | 614-1211-0188-22 | Samata Dey.           |
| 35 | 22035 | SANCHITA PAL         | 222614-11-0012 | 614-1211-0023-22 | Sanchita Pal          |
| 36 | 22036 | SNEHA DAS            | 222614-11-0202 | 614-1212-0176-22 |                       |
| 37 | 22037 | SNEHA DEY            | 222614-11-0053 | 614-1211-0080-22 | Sneha Dey.            |
| 38 | 22038 | SNEHA KOLEY          | 222614-11-0041 | 614-1211-0063-22 | Sneha Koley           |
| 39 | 22039 | SONALI GHOSH         | 222614-11-0250 | 614-1214-0221-22 | Sonali Ghosh          |
| 40 | 22040 | SUCHARITA KHAN       | 222614-11-0284 | 614-1242-0042-22 | Sucharita Khan        |
| 41 | 22041 | SUPARNA MALIK        | 222614-11-0195 | 614-1212-0138-22 | Suparna malik         |
| 42 | 22042 | SWASTIKA CHAKRABORTY | 222614-11-0087 | 614-1211-0140-22 | Swastika Chakraborty. |
| 43 | 22043 | TANU MONDAL          | 222614-11-0016 | 614-1211-0029-22 | Tanu Mondal.          |
| 44 | 22044 | TANUSHRI DAS         | 222614-11-0217 | 614-1212-0272-22 | Tanushri Das.         |
| 45 | 22045 | TUHINA DAS           | 222614-11-0171 | 614-1211-0283-22 | Tuhina Das.           |
| 46 | 22046 | ANKITA DEBNATH       | 223614-11-0003 | 614-1211-0287-22 |                       |
| 47 | 22047 | ANUSHREE DUTTA       | 223614-11-0004 | 614-1211-0288-22 | Anushree Dutta        |
| 48 | 22048 | ARPITA JHA           | 223614-11-0011 | 614-1211-0301-22 | Arpita Jha            |
| 49 | 22050 | POUSALI SARKAR       | 223614-11-0010 | 614-1211-0300-22 | Pousali Sarkar        |
| 50 | 22051 | RAJNI SINGH          | 223614-11-0005 | 614-1211-0290-22 | Rajni Singh           |
| 51 | 22052 | SUCHETA KUNDU        | 223614-11-0024 | 614-1214-0311-22 | Sucheta Kundu         |
| 52 | 22053 | SVETLANA MUKHERJEE   | 223614-11-0001 | 614-1211-0285-22 |                       |
| 53 | 22054 | ANUSHREE SANTRA      | 222614-11-0045 | 614-1211-0069-22 | Anushree Santra.      |
| 54 | 22055 | ARCHANA KUMARI SINGH | 222614-11-0098 | 614-1211-0161-22 | Archana Kumari Singh  |
| 55 | 22056 | ARPITA JANA          | 222614-11-0146 | 614-1211-0237-22 | Arpita Jana           |
| 56 | 22057 | BAISHAKHI GHOSH      | 222614-11-0101 | 614-1211-0168-22 | Baishakhi Ghosh       |
| 57 | 22058 | BARNALI CHAKRABORTY  | 222614-11-0076 | 614-1211-0118-22 | Barnali Chakraborty.  |
| 58 | 22059 | BILKIS KHATUN        | 222614-11-0133 | 614-1211-0218-22 |                       |
| 59 | 22060 | DISHA PAL            | 222614-11-0114 | 614-1211-0187-22 | Disha Pal             |
| 60 | 22061 | DONA BAG             | 222614-11-0046 | 614-1211-0070-22 | Dona Bag              |
| 61 | 22062 | ESA BODAK            | 222614-11-0173 | 614-1212-0001-22 | Esa Bodak             |
| 62 | 22063 | ISHANI DEBNATH       | 222614-11-0060 | 614-1211-0092-22 | Ishani Debnath.       |
| 63 | 22064 | JAYITA PARAMANICK    | 222614-11-0248 | 614-1214-0212-22 | Jayita Paramanick     |
| 64 | 22065 | KABERI SEN           | 222614-11-0107 | 614-1211-0178-22 | Kaberi Sen            |
| 65 | 22066 | KAM                  | 222614-11-0122 | 614-1211-0201-22 | Kamalika Jana         |
| 66 | 22067 | LATII                | 222614-11-0183 | 614-1212-0073-22 | Latika Kewui          |

Soma Roy.  
Principal

Serampore Girls' College  
Serampore, Hooghly

## BA BSc Honours : 2nd Semester 2023

| SL | Roll  | Name                | ENVS Project Submission |                  |                      |
|----|-------|---------------------|-------------------------|------------------|----------------------|
|    |       |                     | CU Roll                 | CU Reg           | Signature            |
| 67 | 22068 | LISHA PAUL          | 222614-11-0026          | 614-1211-0041-22 | Lisha Paul           |
| 68 | 22069 | MOUMITA BAKULI      | 222614-11-0253          | 614-1214-0242-22 | Moumita Bakuli       |
| 69 | 22070 | MOUMITA MAITY       | 222614-11-0124          | 614-1211-0204-22 | Moumita Maity        |
| 70 | 22071 | NEHA DUTTA          | 222614-11-0007          | 614-1211-0015-22 | Neha Dutta           |
| 71 | 22072 | NISHA RAVIDAS       | 222614-11-0153          | 614-1211-0251-22 | Nisha Ravidas.       |
| 72 | 22073 | PONNA BHOWMIK       | 222614-11-0009          | 614-1211-0018-22 |                      |
| 73 | 22074 | POULAMI BAG         | 222614-11-0193          | 614-1212-0130-22 | Poulami Bag          |
| 74 | 22075 | PRATYASHA GHOSH     | 222614-11-0057          | 614-1211-0088-22 | Pratyasha Ghosh.     |
| 75 | 22076 | PRITHA MRIDHA       | 222614-11-0111          | 614-1211-0183-22 | Pritha Mridha        |
| 76 | 22077 | PRITY KUMAR MAHATO  | 222614-11-0137          | 614-1211-0223-22 | Prity Kumari Mahato. |
| 77 | 22078 | PRIYA GHOSH         | 222614-11-0069          | 614-1211-0105-22 | Priya Ghosh.         |
| 78 | 22079 | PRIYANKA MAHATO     | 222614-11-0149          | 614-1211-0243-22 | Priyanka Mahato      |
| 79 | 22080 | PUNAM UPADHYAY      | 222614-11-0151          | 614-1211-0246-22 | Punam Upadhyay       |
| 80 | 22081 | RAHOMOTI KHATUN     | 222614-11-0125          | 614-1211-0205-22 | Rahomoti Khatur      |
| 81 | 22082 | RIMA HAZRA          | 222614-11-0234          | 614-1214-0115-22 | Rima Hazra           |
| 82 | 22083 | RIPTI DAS           | 222614-11-0167          | 614-1211-0273-22 | Ripti Das.           |
| 83 | 22084 | RIYA PAUL           | 222614-11-0117          | 614-1211-0193-22 | Riya Paul.           |
| 84 | 22085 | RIYA SIKDAR         | 222614-11-0184          | 614-1212-0082-22 | Riya Sikdar          |
| 85 | 22086 | RUPSA GHOSH         | 222614-11-0157          | 614-1211-0256-22 | Rupsa Ghosh          |
| 86 | 22087 | RUPSA MONDAL        | 222614-11-0072          | 614-1211-0110-22 | Rupsa Mondal.        |
| 87 | 22088 | SATHI ROY           | 222614-11-0142          | 614-1211-0232-22 | Sathi Roy            |
| 88 | 22089 | SHATAVISHA BANERJEE | 222614-11-0100          | 614-1211-0164-22 | Shatavisha Banerjee  |
| 89 | 22090 | SHRESTHA CHATTERJEE | 222614-11-0020          | 614-1211-0035-22 | Shrestha Chatterjee. |
| 90 | 22091 | SHREYA GHOSH        | 222614-11-0233          | 614-1214-0111-22 | Shreya Ghosh.        |
| 91 | 22092 | SILPI MITRA         | 222614-11-0116          | 614-1211-0190-22 | Silpi Mitra          |
| 92 | 22093 | SNEHA PAUL          | 222614-11-0152          | 614-1211-0249-22 | Sneha Paul           |
| 93 | 22094 | SNEHA SAHA          | 222614-11-0068          | 614-1211-0104-22 | Sneha Saha           |
| 94 | 22095 | SORMISTRA MONDAL    | 222614-11-0216          | 614-1212-0269-22 | Sormistra Mondal.    |
| 95 | 22096 | SOUMI GHOSH         | 222614-11-0118          | 614-1211-0194-22 | Soumi Ghosh          |
| 96 | 22097 | SUDESHNA GHOSH      | 222614-11-0135          | 614-1211-0220-22 | Sudeshna Ghosh       |
| 97 | 22098 | SUKANYA DAS         | 222614-11-0207          | 614-1212-0196-22 | Sukanya Das          |
| 98 | 22099 | SUMANA PANDIT       | 222614-11-0185          | 614-1212-0083-22 | Sumana Pandit        |
| 99 | 22100 | SWAGATA HAZRA       | 222614-11-0215          | 614-1212-0250-22 | Swagata Hazra        |

Soma Roy,  
Principal  
Serampore Girls' College  
Serampore, Hooghly

## BA BSc Honours : 2nd Semester 2023

### ENVS Project Submission

| SL  | Roll  | Name                | CU Roll        | CU Reg           | Signature            |
|-----|-------|---------------------|----------------|------------------|----------------------|
| 100 | 22101 | TIASA DEB           | 222614-11-0034 | 614-1211-0053-22 | Tiasa Deb            |
| 101 | 22102 | TINA DUTTA          | 222614-11-0235 | 614-1214-0120-22 | Tina Dutta           |
| 102 | 22103 | TINA SANTRA         | 222614-11-0071 | 614-1211-0108-22 | Tina Santra          |
| 103 | 22104 | TITHI KHAN          | 222614-11-0213 | 614-1212-0239-22 | Tithi Khan           |
| 104 | 22105 | TITLI DAS           | 222614-11-0257 | 614-1214-0265-22 | Titli Das            |
| 105 | 22106 | AFREEN ANSARI       | 222614-11-0271 | 614-1215-0146-22 | Afreen Ansari        |
| 106 | 22107 | AFRIN KHATOON       | 222614-11-0269 | 614-1215-0131-22 |                      |
| 107 | 22108 | ANANYA ADAK         | 222614-11-0039 | 614-1211-0058-22 | Ananya Adak          |
| 108 | 22109 | ANKITA DAS          | 222614-11-0079 | 614-1211-0124-22 | Ankita Das           |
| 109 | 22110 | ANTARA HALDER       | 222614-11-0214 | 614-1212-0247-22 | Antara Halder        |
| 110 | 22111 | ARPITA MONDAL       | 222614-11-0190 | 614-1212-0106-22 | Arpita Mondal        |
| 111 | 22112 | BEDISHA DEY         | 222614-11-0139 | 614-1211-0227-22 | Bedisha Dey          |
| 112 | 22113 | DARAKHSHAN IFTEKHAR | 222614-11-0276 | 614-1215-0235-22 | Darakhshan Iftekhari |
| 113 | 22114 | DHATRI BISWAS       | 222614-11-0204 | 614-1212-0181-22 | Dhatree Biswas       |
| 114 | 22115 | DIPANWITA BISWAS    | 222614-11-0021 | 614-1211-0036-22 | Dipanwita Biswas     |
| 115 | 22116 | DIYA DAS            | 222614-11-0218 | 614-1212-0280-22 | Diya Das             |
| 116 | 22117 | DONA KARMAKAR       | 222614-11-0252 | 614-1214-0228-22 | Dona Karmakar        |
| 117 | 22118 | ISHITA DAS          | 222614-11-0004 | 614-1211-0008-22 | Ishita Das           |
| 118 | 22119 | KOYEL ROY           | 222614-11-0208 | 614-1212-0200-22 | Koyel Roy            |
| 119 | 22120 | KULSUMA KHATUN      | 222614-11-0263 | 614-1215-0045-22 | Kulsuma Khatun       |
| 120 | 22121 | LAEBA NOOR          | 222614-11-0270 | 614-1215-0133-22 | Laeba Noor           |
| 121 | 22122 | LOPAMUDRA JAISWAL   | 222614-11-0106 | 614-1211-0174-22 | Lopamudra Jaiswal    |
| 122 | 22123 | MASHKURATUN NAMIRA  | 222614-11-0094 | 614-1211-0153-22 | Mashkuratun Namira   |
| 123 | 22124 | MEGHA GIRI          | 222614-11-0011 | 614-1211-0022-22 | Megha Giri           |
| 124 | 22125 | MOUPIRYA BHUL       | 222614-11-0243 | 614-1214-0159-22 | Moupiya Bhul         |
| 125 | 22126 | MOUSUMI PATRA       | 222614-11-0150 | 614-1211-0245-22 | Mousumi Patra        |
| 126 | 22127 | MUSKAN KHATOON      | 222614-11-0086 | 614-1211-0139-22 | Muskan Khatun        |
| 127 | 22128 | PALLAVI CHOUDHARY   | 222614-11-0169 | 614-1211-0279-22 | Pallavi Choudhary    |
| 128 | 22129 | PRAKITI DAS         | 222614-11-0196 | 614-1212-0154-22 | Prakiti Das          |
| 129 | 22130 | PRITI KUMARI SHAW   | 222614-11-0236 | 614-1214-0125-22 | Priti Kumari Shaw    |
| 30  | 22131 | PRITI KUMARI YADAV  | 222614-11-0251 | 614-1214-0225-22 | Priti Kumari Yadav   |
| 31  | 22132 | RITOJA DEY          | 222614-11-0285 | 613-1211-0348-21 | Ritoja Dey           |
| 32  | 22133 | RIYA DHARA          | 222614-11-0200 | 614-1212-0171-22 | Riya Dhara           |

Soma Roy,  
Principal  
Serampore Girls' College  
Serampore, Hooghly

## BA BSc Honours : 2nd Semester 2023

### ENVS Project Submission

| Sl  | Roll  | Name               | CU Roll        | CU Reg           | Signature          |
|-----|-------|--------------------|----------------|------------------|--------------------|
| 133 | 22134 | RUMA BANDURI       | 222614-11-0244 | 614-1214-0185-22 | Ruma Banduri       |
| 134 | 22135 | SAHELI GHOSH       | 222614-11-0105 | 614-1211-0173-22 | Saheli Ghosh       |
| 135 | 22136 | SAMRIDDHI SARKAR   | 222614-11-0206 | 614-1212-0191-22 | Samriddhi Sarkar   |
| 136 | 22137 | SARMIN YEASMIN     | 222614-11-0126 | 614-1211-0206-22 | Sarmin Yeasmin     |
| 137 | 22138 | SAYANI DAS         | 222614-11-0205 | 614-1212-0189-22 | Sayani Das         |
| 138 | 22139 | SAYANTI DAS        | 222614-11-0042 | 614-1211-0064-22 | Sayanti Das        |
| 139 | 22140 | SHOAIBA SHAMIM     | 222614-11-0163 | 614-1211-0266-22 | Shoaiba Shamim     |
| 140 | 22141 | SHREYA ROY         | 222614-11-0108 | 614-1211-0179-22 | Shreya Roy         |
| 141 | 22142 | SNEHA DAS          | 222614-11-0197 | 614-1212-0165-22 | Sneha Das          |
| 142 | 22143 | SNEHA DOLUI        | 222614-11-0038 | 614-1211-0057-22 | Sneha Dolui        |
| 143 | 22144 | SNEHA SARKAR       | 222614-11-0160 | 614-1211-0262-22 | Sneha Sarkar       |
| 144 | 22145 | SOUMILI MANDAL     | 222614-11-0138 | 614-1211-0224-22 | Soumili Mandal     |
| 145 | 22146 | SUDIPTA GHOSH      | 222614-11-0237 | 614-1214-0128-22 | Sudipta Ghosh      |
| 146 | 22147 | SUMAN SHAW         | 222614-11-0241 | 614-1214-0151-22 | Suman Shaw         |
| 147 | 22148 | SUNANDA SHAW       | 222614-11-0168 | 614-1211-0274-22 | Sunanda Shaw       |
| 148 | 22149 | SWASTIKA KARMAKAR  | 222614-11-0242 | 614-1214-0157-22 | Swastika karmakar  |
| 149 | 22150 | TANAYA GHOSH       | 222614-11-0088 | 614-1211-0142-22 | Tanaya Ghosh       |
| 150 | 22151 | TANUSHREE KUMAR    | 222614-11-0049 | 614-1211-0075-22 | Tanushree kumar    |
| 151 | 22152 | TINA MALIK         | 222614-11-0210 | 614-1212-0226-22 | Tina Malik         |
| 152 | 22153 | TIYASA PAUL        | 222614-11-0159 | 614-1211-0261-22 | Tiyasa Paul        |
| 153 | 22154 | ADITI BAG          | 222614-11-0103 | 614-1211-0170-22 | Aditi Bag          |
| 154 | 22155 | AHANA DUTTA        | 222614-11-0259 | 614-1214-0281-22 | Ahana Dutta        |
| 155 | 22156 | ANANYA DAS         | 223614-11-0014 | 614-1211-0308-22 | Ananya Das         |
| 156 | 22157 | ANKITA CHAKRABORTY | 223614-11-0008 | 614-1211-0297-22 | Ankita Chakraborty |
| 157 | 22158 | ANTARA GHANTA      | 223614-11-0012 | 614-1211-0306-22 | Antara Ghanta      |
| 158 | 22159 | APARNA PAL         | 222614-11-0231 | 614-1214-0103-22 | Aparna pal         |
| 159 | 22160 | ARPITA MALIK       | 223614-11-0021 | 614-1212-0305-22 | Arpita Malik       |
| 160 | 22161 | JAYASHREE GHOSH    | 222614-11-0112 | 614-1211-0184-22 | Jayashree Ghosh    |
| 161 | 22162 | KOMAL SHARMA       | 223614-11-0016 | 614-1212-0291-22 | Komal Sharma       |
| 162 | 22163 | KOYEL KARMAKAR     | 222614-11-0258 | 614-1214-0275-22 | Koyel Khan         |
| 163 | 22164 | KOYEL KHAN         | 223614-11-0009 | 614-1211-0298-22 | Koyel Khan         |
| 164 | 22165 | MUNMUN GHOSH       | 223614-11-0013 | 614-1211-0307-22 | Munmun Ghosh       |
| 165 | 22166 | NAJIYA KALIM       | 223614-11-0025 | 614-1215-0289-22 | Najiya Kalim       |

# BA BSc Honours : 2nd Semester 2023

## ENVS Project Submission

| Roll | Name                    | CU Roll        | CU Reg           | Signature               |
|------|-------------------------|----------------|------------------|-------------------------|
| 166  | NASIMA KHATOON          | 223614-11-0026 | 614-1215-0299-22 | Nasima Khatoon          |
| 167  | NISHA PAL               | 223614-11-0002 | 614-1211-0286-22 | Nisha Pal               |
| 168  | PRIYA PAL               | 222614-11-0247 | 614-1214-0208-22 | Priya Pal               |
| 169  | PURNIMA SAHANI          | 223614-11-0020 | 614-1212-0303-22 | Purnima Sahani          |
| 170  | RESHMA KHATUN           | 222614-11-0097 | 614-1211-0160-22 | Reshma Khatun           |
| 171  | RIYA BAG                | 222614-11-0113 | 614-1211-0186-22 | Riya Bag.               |
| 172  | RUBI MONDAL             | 223614-11-0018 | 614-1212-0295-22 | Rubi Mondal             |
| 173  | SAHELI DAS              | 222614-11-0186 | 614-1212-0085-22 | Saheli Das              |
| 174  | SAHINA SULTANA          | 223614-11-0027 | 614-1215-0302-22 |                         |
| 175  | SANA PARWEEN            | 222614-11-0277 | 614-1215-0253-22 | Sana Parween            |
| 176  | SAYANI HALDER           | 223614-11-0017 | 614-1212-0293-22 | Sayani Halder           |
| 177  | SAYANTIKA DAS           | 222614-11-0127 | 614-1211-0207-22 | Sayantika Das           |
| 178  | SAYANTIKA DEY           | 222614-11-0047 | 614-1211-0071-22 | .                       |
| 179  | SEEMI PARWEEN           | 222614-11-0268 | 614-1215-0117-22 | Seemi Parween           |
| 180  | SNEHA SHAW              | 223614-11-0015 | 614-1211-0309-22 | Sneha Shaw              |
| 181  | SNEHASHREE SADHUKHAN    | 223614-11-0022 | 614-1214-0304-22 | Snehashree Sadhukhan    |
| 182  | SONALI SADHUKHAN        | 223614-11-0023 | 614-1214-0310-22 | Sonali Sadhukhan        |
| 183  | SUDESHNA AUDDY          | 223614-11-0006 | 614-1211-0292-22 | Sudeshna Auddy          |
| 184  | SUDESHNA SANTRA         | 222614-11-0203 | 614-1212-0177-22 | Sudeshna Santra         |
| 185  | SUMANA SARKAR           | 223614-11-0019 | 614-1212-0296-22 | Sumana Sarkar           |
| 186  | SUSMITA PAKHIRA         | 222614-11-0102 | 614-1211-0169-22 |                         |
| 187  | TITHI KOLEY             | 223614-11-0007 | 614-1211-0294-22 | Tithi Koley             |
| 188  | AMBARI NESA             | 222614-11-0099 | 614-1211-0162-22 | Ambasi Nesa             |
| 189  | ASMA KHATUN             | 222614-11-0162 | 614-1211-0264-22 | Asma Khatun             |
| 190  | BIDISHA SARKAR          | 222614-11-0175 | 614-1212-0014-22 | Bidisha Sarkar          |
| 191  | DEBLEENA SARKAR         | 222614-11-0179 | 614-1212-0033-22 | Debleena Sarkar         |
| 192  | DEBOSMITA BHATTACHARJEE | 222614-11-0128 | 614-1211-0209-22 | Debosmita Bhattacharjee |
| 193  | DIYA DEY                | 222614-11-0019 | 614-1211-0032-22 | Diya Dey                |
| 194  | JASMINE NEGAR           | 222614-11-0155 | 614-1211-0254-22 |                         |
| 195  | JAYEETA SARDAR          | 222614-11-0222 | 614-1213-0270-22 | Jayeeta Sardar          |
| 196  | KAINAT ANJUM            | 222614-11-0278 | 614-1215-0259-22 |                         |
| 197  | KAJAL DALUI             | 222614-11-0174 | 614-1212-0003-22 | Kajal Dalui             |
| 198  | KANCHAN MALI            | 222614-11-0255 | 614-1214-0248-22 | Kanchan Mali            |

Soma Roy,  
Principal  
Serampore Girls' College  
Serampore, Hooghly

## BA BSc Honours : 2nd Semester 2023

### ENVS Project Submission

| Roll | Name                     | CU Roll        | CU Reg           | Signature          |
|------|--------------------------|----------------|------------------|--------------------|
| 98   | 22299 BAISHAKHI PAL      | 222614-11-0066 | 614-1211-0101-22 | Baishakhi Pal      |
| 99   | 22300 BITHIKA SARKAR     | 222614-11-0212 | 614-1212-0238-22 | Bithika Sarkar.    |
| 00   | 22301 CHANDRIMA PATRA    | 222614-11-0283 | 614-1241-0004-22 | Chandrima Patra.   |
| 01   | 22302 DEBAPRIYA KOLE     | 222614-11-0090 | 614-1211-0144-22 |                    |
| 02   | 22303 LAKSHMI MONDAL     | 222614-11-0188 | 614-1212-0096-22 | Lakshmi Mondal.    |
| 03   | 22304 MALLIKA DAS        | 222614-11-0050 | 614-1211-0076-22 | Mallika Das        |
| 04   | 22305 MONISHA DAS        | 222614-11-0110 | 614-1211-0182-22 | Monisha Das.       |
| 05   | 22306 RITU DEY           | 222614-11-0081 | 614-1211-0127-22 | Ritu Dey.          |
| 06   | 22307 ROBINA GHOSH       | 222614-11-0223 | 614-1214-0005-22 | Robina Ghosh       |
| 07   | 22308 SANKHAONI DAS      | 222614-11-0140 | 614-1211-0230-22 | Sankhaoni Das      |
| 08   | 22309 SONALI DAS         | 222614-11-0089 | 614-1211-0143-22 |                    |
| 09   | 22310 SWATHI SAMANTA     | 222614-11-0091 | 614-1211-0145-22 | Swathi Samanta     |
| 10   | 22312 SULAGNA CHATTERJEE | 222614-11-0172 | 614-1211-0284-22 | Sulagna Chatterjee |
| 11   | 22420 ANUSHREE DAS       | 222614-11-0161 | 614-1211-0263-22 |                    |
| 12   | 22709 SNEHA PALIT        | 222614-11-0077 | 614-1211-0121-22 | Sneha Palit        |
| 13   | 22727 SUMAN KUMARI GUPTA | 222614-11-0165 | 614-1211-0268-22 | Suman Kumari Gupta |

Soma Roy.  
Principal  
Serampore Girls' College  
Serampore, Hooghly

Soma Roy.  
Principal  
Serampore Girls' College  
Serampore, Hooghly

# UNIVERSITY OF CALCUTTA

SERAMPORE GIRLS COLLEGE

APARNA MALIK

SEMESTER :- 2nd

COLLEGE ROLL :- 22007

C.U ROLL :- 222614-11-0194

C.U REGISTRATION NO :- 614-1212-0137-22

DEPARTMENT :- BENGALI HONOURS

SUBJECT :- ENVIRONMENTAL STUDIES

PAPER :- AECC2

TOPIC :- STUDY OF COMMON BIRDS IN YOUR LOCALITIES

DATE :- 12.07.2023



KEA

Soma Roy,  
Principal  
Serampore Girls' College  
Serampore, Hooghly

TITLE

SOME COMMON

BIRDS IN OUR

LOCALITIES

JAGANNATHPUR

Project work/field work/ internships  
Name of Course: COMPUTER SCIENCE HONOURS PROJECT  
Code: CC13 and CC14 (Honours)  
Department: Computer Science  
2022-2023

## Criteria 1.3.2



## Serampore Girls College

13, T.C. Goswami Street,  
Serampore, Hooghly – 712201, West Bengal  
Re- Accredited by NAAC : Grade B (2nd Cycle)  
Email: [serampore\\_girls\\_college@yahoo.co.in](mailto:serampore_girls_college@yahoo.co.in)  
Website: [www.seramporegirlscollege.org](http://www.seramporegirlscollege.org)

# Serampore Girls' College

13, T.C. Goswami Street Serampore Hooghly - 712201 West Bengal

## NAAC Criteria 1.3.2



## PROJECT WORK REPORT 2022-2023

### REPORT ON PROJECT WORK OF CC13 and CC14 (COMPUTER SCIENCE)

Academic Session: 2022-2023

SEMSTER: VI ( HONOURS)

**Name of Course: PROJECT WORK**

**Code: CC13 & CC14**

**Location: Serampore Girls' College, WEST BENGAL**

**Course Objective:**

Students will learn about software or website making steps.. Also know about the software maintenance.

**Date of report submission:** yet not submitted (exam will be conducted on 3<sup>rd</sup> August,2023.

**Duration:** 6 months ( 1 semester)

**students enrolled:** 8

**Student submitted:.**8

**Guided by:**

Moumita Ghosal ( Department of Computer Science, Serampore Girls' College)

**Course Outcome:**

- Students were able to learn basic software making details and presentation.

*Soma Roy.*  
Principal  
Serampore Girls' College  
Serampore, Hooghly



### SYLLABUS OF THE COURSE

- N Chandrasekharan, 3<sup>rd</sup> Edition, PHI.  
 3. Introduction to Theory of Computation by Micheal Sipser, 3<sup>rd</sup> Edition, Cengage Learning.  
 4. Switching and Finite Automata Theory by Zvi Kohavi, Niraj K. Jha, 3<sup>rd</sup> Edition, TMH.  
 5. Formal Language and Automata, P. Linz, Narosa

#### **CMS-A-CC-6-14-P: Project Work**

**Core Course-14, Practical, Credit:04, Contact hours: 60.**

Candidates have to do their project in any relevant topic, under the supervision of teachers.

#### **Discipline Specific Elective Course A: DSE-A**

**CMS-A-DSE-A-3-TH: Embedded Systems**

**DSE-A: Choice-3: Theory, Credit:04, Contact hours: 60.**

|  |                 |
|--|-----------------|
| <b>Introduction to 8051</b><br>Overview of Microcontroller, Memory, I/O interface<br>Intel Microcontroller 8051: Architecture, Peripheral Interface Controller (PIC).  | <b>15 hours</b> |
| <b>Assembly Language Programming</b><br>Instruction set, Addressing Modes, Jump, Loop and Call instructions, I/O Manipulation, Serial communication, Arithmetic and logical instructions.  | <b>10 hours</b> |
| <b>Introduction to Embedded System Programming</b><br>Data types and time delays, I/O programming, Logic operations, Data conversions, Data serialization, Interrupt programming, LCD and Keyboard interfacing, ADC, DAC, sensors interfacing, interfacing 8255, I/O interfacing for 8051, interfacing 8255, 8257, 8259/ 8279, ADC, DAC, Motor control using 8051 C. | <b>15 hours</b> |
| <b>Programmable logic devices and Hardware description Language</b><br>PAL, PLA, PLD, ASIC, FPGA (Qualitative study).  | <b>10 hours</b> |
| <b>Hardware Description Language (VHDL):</b><br>Basic Terminology, Entity Declaration, Architecture body, Configuration and package declaration, Package body, Model analysis and Simulation.<br>Basic Language elements, Behavioral Model, Dataflow Model, Structural Model, Subprogram and overloading, Applications.  | <b>15 hours</b> |

#### **CMS-A-DSE-A-3-P: Embedded Systems Lab.**

**DSE-A: Choice-3, Practical, Credit: 02, Contact hours: 40 hours**

**Practical:** Sample practical problems can be included related to theory.

1. Assembly Language Programming related to Microcontroller 8051.
2. Programming Using Embedded C for 8051.
3. VHDL programs for construction and simulation of various digital circuits.

# Serampore Girls' College

13, T.C. Goswami Street Serampore Hooghly - 712201 West Bengal

## NAAC Criteria 1.3.2



### NOTICE FOR THE PROJECT

nm

**Serampore Girls' College**  
(Est. : 1981)  
Accredited by NAAC  
13, T. C. GOSWAMI STREET, SERAMPORE, HOOGHLY, PIN-712 201, WEST BENGAL.  
Ph: (033) 2652 9334 • (033) 2652781 (Principal) • 26623723 (Office) • 2652-0008  
E-mail : science@seramporegirlscollege.org • sgc.scdept@gmail.com

**Department of SCIENCE**

Ref. No. .... Date. 01.04.2023

**NOTICE**  
**on**  
**Project Work Distribution**

Students of Semester 6 of Computer Science Honours are here by notified that their Project work (Paper CC13 & CC14 Practical) will be done as per following topics.

| Group   | Name of the students              | Project Title                            | Guide              |
|---------|-----------------------------------|--|--------------------|
| Group 1 | Sohinee Sengupta<br>Soma Das      | App Generation                           | Sri Debkanti Das   |
| Group 2 | Prakriti Banerjee<br>Punam Kumari | Student Course<br>Management System      | Sri Anjan Goswami  |
| Group 3 | Ekta Prasad<br>Swati Paswan       | Hotel Reservation<br>System              | Ms. Moumita Ghosal |
| Group 4 | Sathi Som<br>Elisha Mitra         | Student Progression<br>Management System | Ms. Moumita Ghosal |

*Moumita Ghosal*

  
Department of Computer Science  
Serampore Girls' College  
13, T.C. Goswami Street  
Serampore, Hooghly, W.B.  
Pin - 712 201

*Soma Roy*  
Principal  
**Serampore Girls' College**  
Serampore, Hooghly  
Signature of Principal

# SERAMPORE GIRLS' COLLEGE

(ESTD.:1981)



## CERTIFICATE

This is to certify that Soma Das student of  
B.Sc Sem VI Computer Science Honours of Serampore  
Girls' College, Roll No. 203614-11-0021 has  
completed her project titled

Cake & Snacks shop management system

under the guidance of Ms. Moumita Ghosal.

Moumita Ghosal

1.8.23

Signature of the guide



Moumita Ghosal

Signature of Head of the  
Department

# Serampore Girls' College

(Estd: 1981)

Accredited by NAAC

13, T.C. GOSWAMI STREET, SERAMPORE, HOOGHLY, PIN-712201, WEST BENGAL.

Ph: (033) 26529334 • (033) 26527850 (Principal) • 26623723 (Office) • 2652-0008

E-mail : [science@seramporegirlscollege.org](mailto:science@seramporegirlscollege.org) • [sgc.scdept@gmail.com](mailto:sgc.scdept@gmail.com)

## Department of Science

Ref No: \_\_\_\_\_

Date: 1.8.23

### PROJECT COMPLETION CERTIFICATE

#### To Whom It May Concern

This is to certify that Elisha Mitra  
student of B.Sc. Sem VI Computer Science Honours of  
Serampore Girls' College, Roll No. 203614-11-0009  
has completed her project titled Student Progression  
Management System  
under the guidance of Ms. Moumita Ghosal.

Moumita Ghosal.

1.8.23

Signature of the guide  
Serampore Girls' College



Moumita Ghosal

Signature of Head of the  
Departmental  
Serampore Girls' College

Head of the Department  
Department of Computer Science

AWARD LIST OF UNIVERSITY OF CALCUTTA

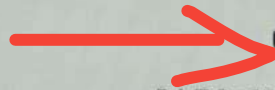

UNIVERSITY OF CALCUTTA

Award List (Practical Examination)  
B.A./B.Sc. SEMESTER - VI (Honours) Examination (Under CBCS), 2023

College/Centre : SERAMPORE GIRLS COLLEGE (614)

Subject : CMSA

Course : CC13

Subject Category : HONOURS

Assessment Type : Practical

Course Name : SOFTWARE ENGINEERING AND PROJECT DESIGN & DOCUMENTATION

Foil No. : 5999

Batch No. : 1

| Srl No. | Roll Numbers   | Registration Numbers | Signature of Candidates | [FM 30]        |            |    |
|---------|----------------|----------------------|-------------------------|----------------|------------|----|
|         |                |                      |                         | Marks Obtained |            |    |
|         |                |                      |                         | Examiner       | Scrutineer | HE |
| 1       | 203614-11-0001 | 614-1211-0297-20     | Sohinee Sengupta        | 27             |            |    |
| 2       | 203614-11-0009 | 614-1211-0306-20     | Elisha Mitra            | 28             |            |    |
| 3       | 203614-11-0014 | 614-1211-0317-20     | Swati Paswan            | 24             |            |    |
| 4       | 203614-11-0020 | 614-1211-0327-20     | Prakruti Banerjee       | 28             |            |    |
| 5       | 203614-11-0021 | 614-1211-0332-20     | Soma Das                | 27             |            |    |
| 6       | 203614-11-0038 | 614-1214-0315-20     | Ekta Prasad             | 24             |            |    |
| 7       | 203614-11-0039 | 614-1214-0319-20     | Sathi Som               | 28             |            |    |
| 8       | 203614-11-0045 | 611-1211-0497-17     | Punam Kumari            | 28             |            |    |

unacad. (Internal)  
Arijit Kamra

Moumita Ghosal. (Internal)  
3.8.23  
Arijit Kamra 03/08/23

Signature of Internal/External Examiner(s)

Signature of Scrutineer(s)

Signature of HE with date & seal

## STUDENTS DURING FINAL PROJECT PRESENTATION

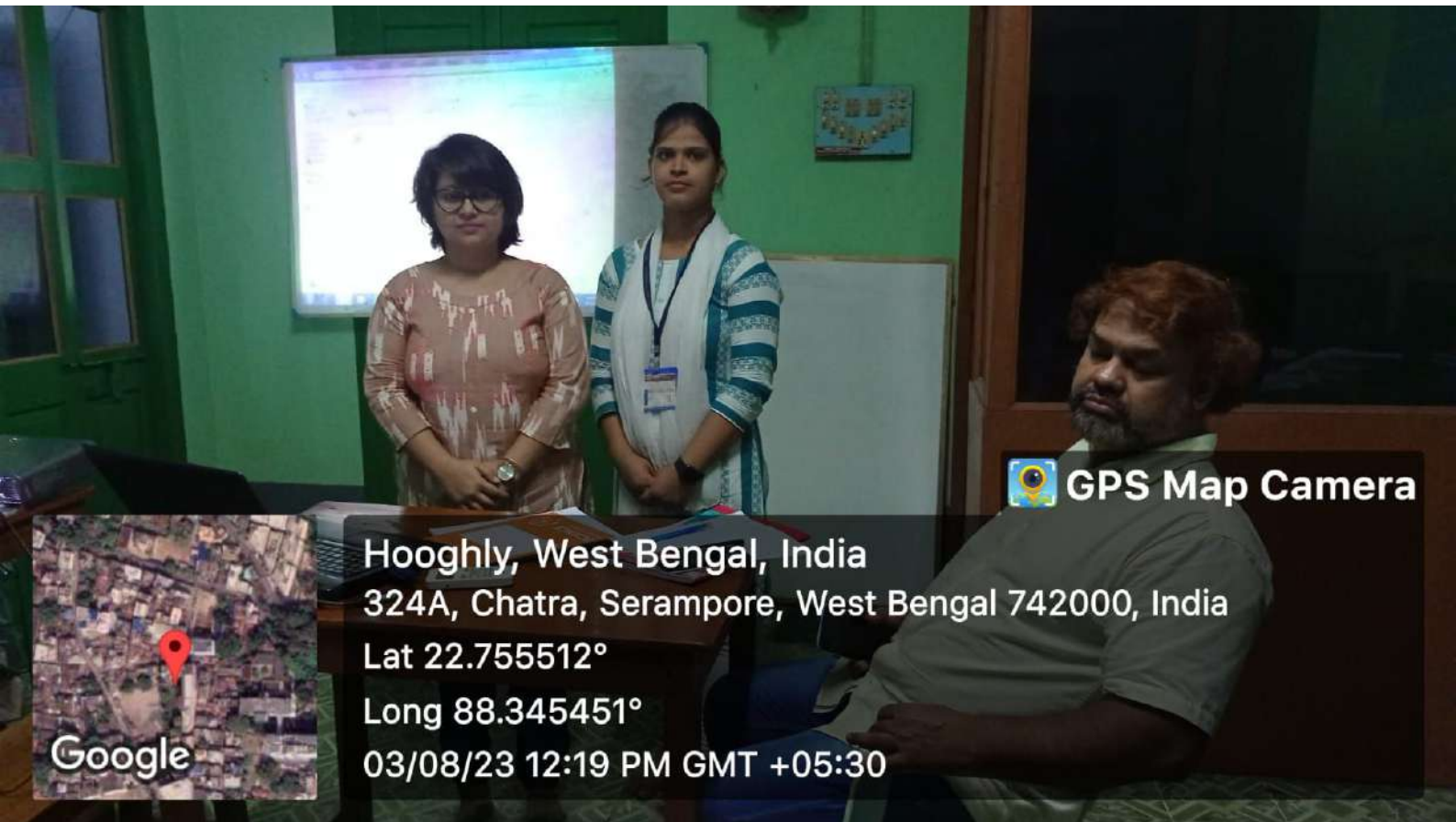

*Soma Roy.*  
Principal  
Serampore Girls' College  
Serampore, Hooghly

## STUDENTS DURING FINAL PROJECT PRESENTATION

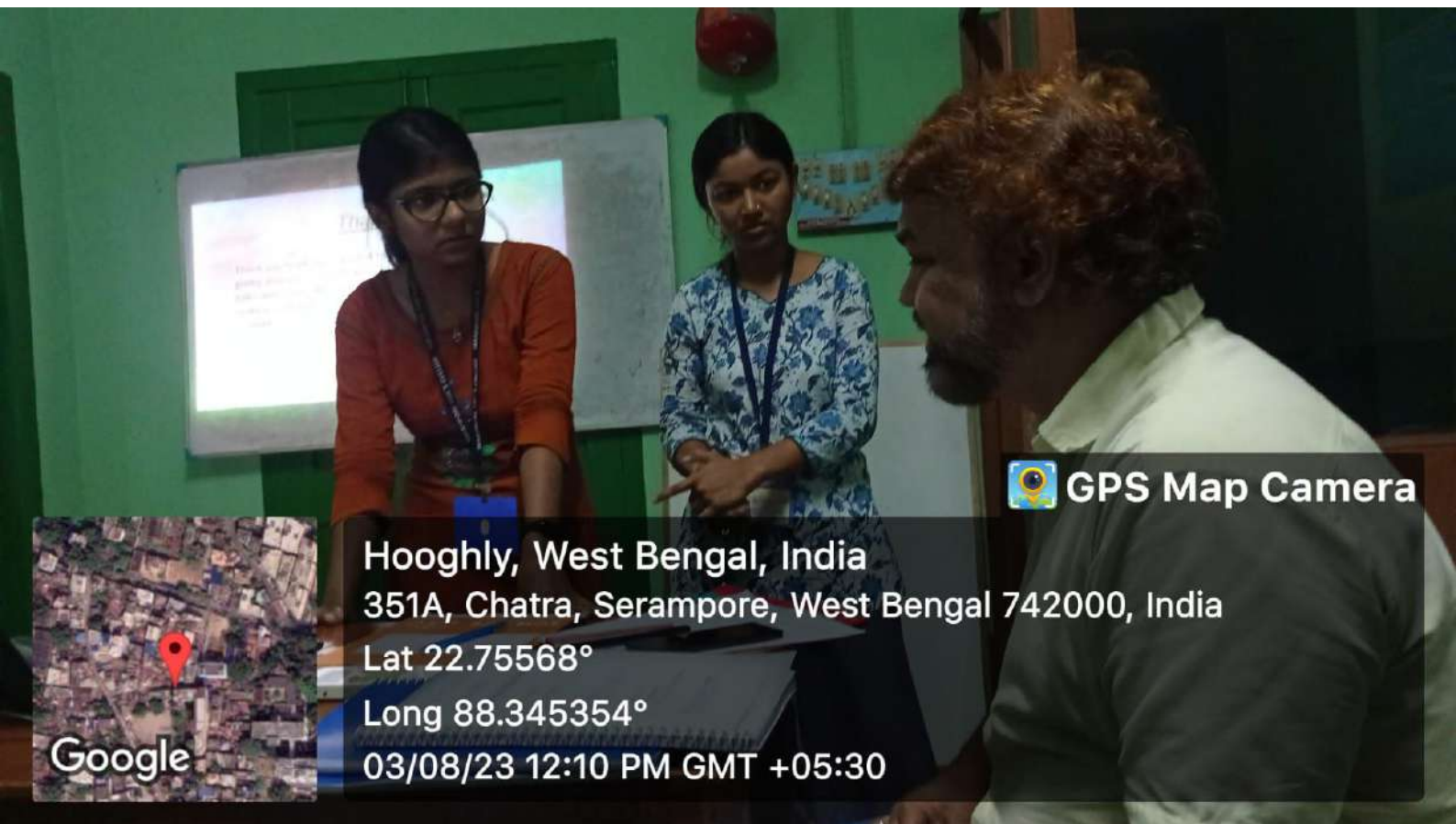

Soma Roy,  
Principal  
Serampore Girls' College  
Serampore, Hooghly

# UNIVERSITY OF CALCUTTA

B.Sc. SEMESTER-VI (HONOURS) Examination-2023

(UNDER CBCS)

**Subject-CMSA CC-13(P)**

**Project Report**

**Student Course Management System**

**Presented By-**

**Prakriti Banerjee**

**Punam Kumari**

**Supervised By:-**

**Mr Anjan Goswami**

# Project Report

## Cake & Snacks Shop management System

*Submitted by*

**Sohinee Sengupta**

Roll Number: 203614-11-0001

Registration Number: 614-1211-0297-20

&

**Soma Das**

Roll Number: 203614-11-0021

Registration Number: 614-1211-0332-20

*Supervised by*

**Ms. Moumita Ghosal**

Assistant Professor,

Department of Computer Science, Serampore Girls' College

*Dept. Of Computer Science*

UNIVERSITY OF CALCUTTA

Project work/field work/ internships  
Name of Course: HAZARD MANAGEMENT LAB  
Code: GEO-A-CC-6-14-P  
Department: GEOGRAPHY  
2022-2023

## Criteria 1.3.2



## Serampore Girls College

13, T.C. Goswami Street,  
Serampore, Hooghly – 712201, West Bengal  
Re- Accredited by NAAC : Grade B (2nd Cycle)  
Email: [serampore\\_girls\\_college@yahoo.co.in](mailto:serampore_girls_college@yahoo.co.in)  
Website: [www.seramporegirlscollege.org](http://www.seramporegirlscollege.org)

# Serampore Girls' College

13, T.C. Goswami Street Serampore Hooghly - 712201 West Bengal

## NAAC Criteria 1.3.1



## PROJECT WORK REPORT 2022-2023

**Department: GEOGRAPHY**

**Academic Session: 2022-2023**

**SEMSTER: VI (SIX)**

**Name of Course: HAZARD MANAGEMENT LAB**

**Code: GEO-A-CC-6-14-P**

**Course Objective:**

Students will learn

· To study geographical presentation of vulnerability of different types of hazard and how to prepare hazard related project reports.

· **Duration:** 6 months

**Students participated:** 31

**Topic:** Flood, Earthquake, Air pollution, Road accident, Landslide.

**Name of Teachers:**

i. Dr Asrafal Alam (Teacher and HOD, Dept of Geography, Serampore Girls' College) ,

iii. Tumpa Hudut (Teacher, Dept of Geography, Serampore Girls' College)

iii. Priyanka Dey (Teacher, Dept of Geography, Serampore Girls' College)

IV. Taniya Kar (Teacher, Dept of Geography, Serampore Girls' College)

V. Moumita Kundu (Teacher, Dept of Geography, Serampore Girls' College)

Assistant:

i. Mr. Tarun Kr. Pal ( Lab Assistant, Dept of Geography, Serampore Girls' College)

**Course Outcome:**

- In this project work students learned about the case study of different areas affected with hazard.
- In this project work students learned to identify the study area which is more or less vulnerable due to hazard.

*Soma Roy,*  
Principal  
Serampore Girls' College  
Serampore, Hooghly

Signature of Principal



### SYLLABUS OF THE COURSE

HONOURS COURSE: CORE SUBJECTS

#### 2.28 GEO-A-CC-6-14-P – Hazard Management Lab ✧ 30 Marks / 2 Credits

A Group Project Report is to be prepared and submitted based on any one case study among the following hazards from West Bengal, incorporating a preparedness plan, preferably in the vicinity of the candidates' institution / district:

1. Earthquake
2. Landslide
3. Land subsidence
4. Thunderstorm
5. Flood
6. Riverbank / Coastal erosion
7. Fire
8. Industrial accident
9. Road / Railway accident
10. Structural collapse
11. Environmental pollution
12. Biohazard

One case study will be done by a group of five to ten students. Different groups may choose different case studies from any one or different types of disasters. The report should be prepared on secondary data and handwritten on A4 page in candidates' own words not exceeding 2,000 words excluding references. The report should contain a proper title. The report should incorporate relevant tables, maps, diagrams, and references, not exceeding ten pages. Photographs are optional and should not exceed three. A copy of the stapled / spiral-bound report in a transparent cover, duly signed by the concerned teacher, is to be submitted during examination. Without the report the candidates will not be evaluated for GEO-A-CC-6-14-P.

Marks division: 20 on report + 10 on viva-voce = 30

Signature of Principal

# Serampore Girls' College

13, T.C. Goswami Street Serampore Hooghly - 712201 West Bengal

## NAAC Criteria 1.3.1



### Sample report

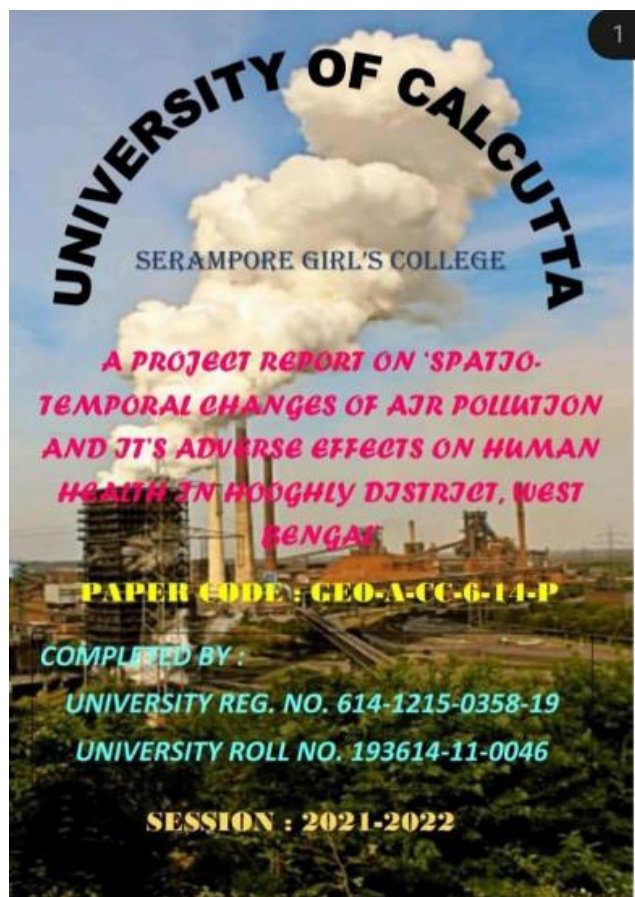

Soma Roy,  
Principal  
Serampore Girls' College  
Serampore, Hooghly

Signature of Principal

Project work/field work/ internships  
Name of Course: Evolution of Geographical Thought Lab  
Code: GEO-A-CC-6-13-P  
Department: GEOGRAPHY  
2022-2023

# Criteria 1.3.2



## Serampore Girls College

13, T.C. Goswami Street,  
Serampore, Hooghly – 712201, West Bengal  
Re- Accredited by NAAC : Grade B (2nd Cycle)  
Email: [serampore\\_girls\\_college@yahoo.co.in](mailto:serampore_girls_college@yahoo.co.in)  
Website: [www.seramporegirlscollege.org](http://www.seramporegirlscollege.org)

# Serampore Girls' College

13, T.C. Goswami Street Serampore Hooghly - 712201 West Bengal

## NAAC Criteria 1.3.1



## PROJECT WORK REPORT 2022-2023

**Department: GEOGRAPHY**

**Academic Session: 2022-2023**

**SEMSTER: VI (SIX)**

**Name of Course: Evolution of Geographical Thought Lab**

**Code: GEO-A-CC-6-13-P**

### **Course Objective:**

Students will learn

- To study geographical presentation and preparation of poster

**Duration:** 6 months

**Students participated:** 31

Topic:,Radicalism.,Possibilism,Behaviourism, Determinism, Humanism.

### **Name of Teachers:**

i. Dr AsrafAlam (Teacher and HOD, Dept of Geography,Serampore Girls' College) ,

iii.TumpaHudut(Teacher, Dept of Geography,Serampore Girls' College)

iii.PriyankaDey (Teacher, Dept of Geography,Serampore Girls' College)

IV. Taniya kar (Teacher, Dept of Geography,Serampore Girls' College)

Project work - poster preparation of geographical thought.

V. Moumita Kundu (Teacher, Dept of Geography.Serampore Girls' College)

### **Assistant:**

i. Mr.Tarun Kr. Pal ( Lab Assistant, Dept of Geography,Serampore Girls' College)

### **Course Outcome:**

- In this project work students learned about the history of geographical knowledge .
- In this project work students learned about the present and past chronological period.

Soma Roy,  
Principal  
Serampore Girls' College  
Serampore, Hooghly



### SYLLABUS OF THE COURSE

HONOURS COURSE: CORE SUBJECTS

#### 2.26 GEO-A-CC-6-13-P – Evolution of Geographical Thought Lab ⇨ 30 Marks / 2 Credits

*A laboratory notebook, comprising class assignments of topics 1 and 2, is to be prepared and submitted. The exercises are to be drawn in pencil with photocopied representation of source materials where necessary. All texts are to be handwritten.*

1. Changing perception of maps of the world (Ptolemy, Ibn Batuta, Mercator)
2. Mapping voyages; Columbus, Vasco da Gama, Magellan, Thomas Cook
3. Group Presentation of five to ten students on any selected school of geographical thought (20 marks)
4. Viva-voce based on laboratory notebook on topics 1 and 2 (10 Marks)

#### References

- Black, J. 2003. Visions of the World: A History of Maps, Mitchell Beazley.
- Couper, P. 2015. A Student's Introduction to Geographical Thought: Theories, Philosophies, Methodologies, Sage.
- Holt-Jensen, A. 2011. Geography: History and Concepts: A Student's Guide, Sage.
- Whitfield, P. 2017. Charting the Oceans, British Library.

# Serampore Girls' College

13, T.C. Goswami Street Serampore Hooghly - 712201 West Bengal

## NAAC Criteria 1.3.1



### POSTER PRESENTATION AND REPORT SUBMISSION TO TEACHER

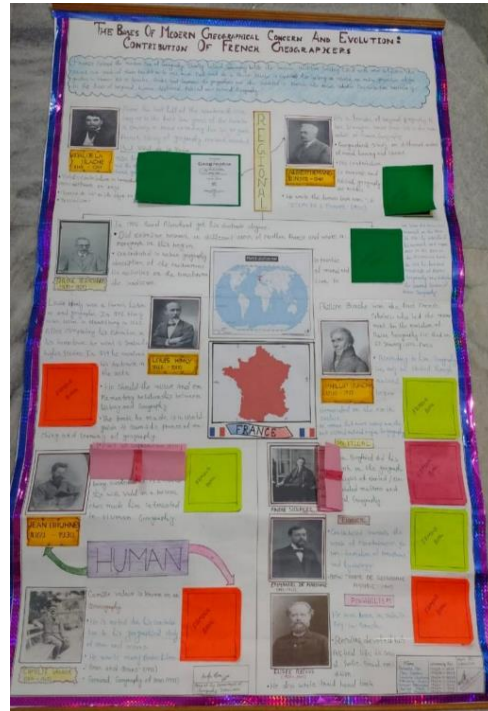

Soma Roy,  
Principal,  
Serampore Girls' College  
Serampore, Hooghly

Project work/field work/ internships  
Name of Course: Sanskrit composition and communication  
Code: SANA CC14  
DEPT: SANSKRIT  
2022-2023

## Criteria 1.3.2

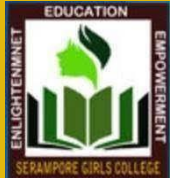

## Serampore Girls College

13, T.C. Goswami Street,  
Serampore, Hooghly – 712201, West Bengal  
Re- Accredited by NAAC : Grade B (2nd Cycle)  
Email: [serampore\\_girls\\_college@yahoo.co.in](mailto:serampore_girls_college@yahoo.co.in)  
Website: [www.seramporegirlscollege.org](http://www.seramporegirlscollege.org)

# Serampore Girls' College

13, T.C. Goswami Street Serampore Hooghly - 712201 West Bengal

## NAAC Criteria 1.3.2



### PROJECT WORK REPORT 2022-2023 (SANSKRIT)

#### SEMESTER - VI (SIX)

**NAME OF COURSE** – Sanskrit composition and communication

**CODE** - SANA CC14

**LOCATION** - Serampore Girls' College

**COURSE OBJECTIVE** - Students will learn

- 1.entertainment
- 2.natianaland international affairs
- 3.social problems

**Date** – EVEN SEMESTER

**Students participated** – 20

**Name of Teachers:**

1. Kabery Hossain(Teacher and HOD,Dept of Sanskrit, Serampore Girls' College)
2. Silpi Adhikari(Teacher,Dept of Sanskrit, Serampore Girls' College)

**Course Outcome** –

1. In this way students learned about the social problems and the method of solution.
- 2.To writing to various aspects of Sanskrit language.

*Soma Roy.*  
Principal  
Serampore Girls' College  
Serampore, Hooghly

Signature of Principal

# Serampore Girls' College

(Estd.: 1981)

Re-Accredited by NAAC : Grade B (2nd Cycle)

13, T. C. GOSWAMI STREET, SERAMPORE, HOOGHLY. PIN-712 201, WEST BENGAL.

E-mail : serampore\_girls\_college@yahoo.co.in

Website : www.seramporegirlscollege.org

Ref. No. ....

Date 13/4/23.....

## NOTICE

It is decided that the project of 6th sem honours students will be submitted in the last week of April on syllabus based topic and Paper- CC-14. Viva date is given below.

CC-14 - Tutorial - Last week of April

CC-14 - Internal - 2nd week of May - This will be held on online mode by viva system according to universities rules.

Silpi Adhinari

Dept. of Sanskrit

## Semester-6: Project submission

## ATTENDANCE

BLANK AWARD LIST

EXAMINATION: Tutorial - 6th Sem

SUBJECT: SANA

SUB CATEGORY: CC-14

ASSESSMENT TYPE: Project

| SL NO. | ROLL NO.       | Signature<br>REGISTRATION NO. | MARKS OBTAINED<br>DATE: |
|--------|----------------|-------------------------------|-------------------------|
| 1.     | 202614-11-0001 | Riya Pal                      | 29.04.2023              |
| 2.     | -0005          | Payel Pal.                    | 29.04.2023              |
| 3.     | -0007          | Riya Nandi.                   | 29.04.2023              |
| 4.     | -0027          | Tuheli Bar                    | 29.04.23                |
| 5.     | -0053          | Priyanka Dutta                | 29.4.23                 |
| 6.     | -0094          | Mayabati Kundu                | 28.4.23                 |
| 7.     | -0096          | Lalita Bharz                  | 28.04.23                |
| 8.     | -0117          | Debasmita Dutta               | 29.04.23                |
| 9.     | -0132          | Sayami Dey                    | 29.04.23                |
| 10.    | -0133          | Pratikha Dey.                 | 29.04.23                |
| 11.    | -0146          | Asroin Khodun                 | 28.4.2023               |
| 12.    | -0166          | Janusree Bhattaohashta        | 6.5.23                  |
| 13.    | -0193          | Neha Mal                      | 29.4.23                 |
| 14.    | -0208          | Tiyasa Santra                 | 29.4.23                 |
| 15.    | -0216          | POJA Dolui                    | 28.4.2023               |
| 16.    | -0223          | Rituparna Sardar.             | 29.4.23                 |
| 17.    | -0228          | Jyotirmoyee Sardar            | 28.04.23                |
| 18.    | -0232          | Panchumi Biscuar              | 6.5.23                  |
| 19.    | -0238          | Puja Bag                      | 29.04.23                |
| 20.    | -0277          | Aishwarya Das                 | 29.04.23                |

## Social Problems

### नारी शिक्षा

1

#### ■ नारी शिक्षार भूमिका :- परिचय :- ■

अस्माकं सामाजिकप्रगतेः आर्थिकविकासाय च महिलाशिक्षा अत्यावश्यकी अस्ति, आधुनिकसमाजस्य मध्ये स्त्रीपुरुषान् अपेक्ष्य सर्वेषां मूलभूताः अधिकाराः समानाः समानाः च भवन्ति, एकविंशतिशतके विश्वं यस्मिन् - सामाजिक - आर्थिक - राजनैतिक - सांस्कृतिक - परिवर्तनेषु भागं गृह्णाति, तेषु महिलाः अनिवार्य - सहभागिनः जितः युद्धस्य भागिज्ञानां, सहचरानाञ्च एकः, परन्तु अज्ञानस्य - अन्धकारे पृष्ठतः - पतन्त्याः स्त्रियाः तां अपेक्षिता भूमिकां कर्तुं न शक्यन्ते, अतः अद्य महिलाशिक्षायाः आग्रहः अस्ति,

■ एवमेव स्नेह - प्रेम - दया - दान्धिष्य - श्रद्धा - भक्ति - स्वास्थ्य - समृद्धि - युक्तः परिवारः, समाजो वा बौद्धिकवियत्रीभिः काङ्क्षितः आसीत्, सर्वोपरि सीमनस्ययुता वाक् परिवारस्य समाजस्य राष्ट्रस्य च संहतिसाधिका इति वागभृण्याः वचनम्, ऋषिपत्नीनां समाजभावना, परिवारसङ्कल्पता, दाम्पत्यकामता विद्वजनीना - सामाजिकी च आसीत्.

कविता कालिदासेन तु नारीणां सर्वाणि रूपाणि एकत्र उद्भावयति - गृहिणी सखिः सखी मिथः प्रियशिष्या ललिता

PTO.

## एशियामहादेशीय क्रीडा: २०१८

भूमिका- समग्र एशियामहादेशस्य समन्वयक्रीडाप्रतियोगिता तथा एशियामहादेशस्य देशेषु मैत्री-सुसम्पर्कस्य च प्रतीकं एशीय-क्रीडा इति, २०१८ ईशवीयब्दे इयं क्रीडा अनुष्ठितमभवत् इन्दोनेशियादेशस्य राजधान्यां जाकार्तानगर्या, दक्षिणसुमात्राप्रदेशस्य राजधान्यां चालेम्बयनगर्याम्, १८ 'आगष्' मासतः २ 'सेप्टेम्बर'मासपर्यन्तं इयं क्रीडा चलित्, २०१४ ईशवीयाब्देमिव अस्मिन् वत्सरे अति-साफल्येन भारतवर्षः अष्टमस्थानं प्राप्ते सन् विगतवत्सात् अस्मिन् वर्षे पदकप्राप्तीनां सुवर्णप्राप्तीनां च संख्याः अधिकाः। विशेषतः महिलाणां साफल्यम् उल्लेखनीयम्।

लक्ष्यम्- एशियात् इयस्य लक्ष्योद्देश्यविषये आदौ - 'विभिन्न-देशेषु स्मारकपत्रिकायाम् अलिखित्, सांस्कृतिकमिलनस्थापनाय सम्राजा अशोकैः एशीयदेशेषु भारतवर्षस्य वाणीप्रेरणार्थं भिक्षुकान् प्रेषितान्। एशीयक्रीडया सम्राजः अशोकस्य स्वप्नः वास्तवायितः भवति', मूलतः भारतवर्षस्य प्रधानमन्त्रिणः जओटूरलालनेट्टेरुमट्टोदयस्य प्रयासेन तथा अध्यापकगुरुदत्त-सोन्धिमट्टोदयस्य अवलम्बनेन इयं क्रीडा आदौ प्रचलित् अभवत्, अस्मिन् कर्मणि अध्यापकसोन्धिमट्टोदयस्य प्रयासेन सह पाकिस्तानमहाराजस्य यादवेन्दूसिमट्टोदयस्य तथा एन्दिनिदिमोलामट्टोदयस्य सहयोगितापि अविस्मरणीयाः। १९४७ ईशवीयब्दे मार्चमासि नेट्टेरुमट्टोदयेन 'Asian Relation Conference' इत्यनेन निमित्तस्य 'Asian Games Federation' इति निमित्तस्य सिद्धन्तम् अगृह्यन्। अस्य सम्मेलनस्य सदस्याः आसीत् पञ्चदेशाः - भारत, पाकिस्तान, म्यान्मार, आफगानिस्तान, फिलिपाइन्स् चेति,

**SYLLABUS**

8. Hiriyanna, M. - Outline of Indian Philosophy, London, 1956 (also Hindi Translation).
9. Radhakrishnan, S. - Indian Philosophy, Oxford University Press, Delhi, 1990.
10. Chatterjee, S.C. : Introduction to Indian Philosophy, Calcutta
11. D.M. Dutt (हिन्दी अनुवाद) भारतीय दर्शन
12. Bhattacharya, Chandrodaya, The Elements of Indian Logic and Epistemology,
13. Maitra, S.K., Fundamental Questions of Indian Metaphysics & Logic
14. Jha, V. N., Tarkasaṃgraha of Annambhaṭṭa ( English Translation with Notes), CIFSS, Kerala (India),2016 (2<sup>nd</sup> Ed.)
15. तर्कसंग्रह, (अध्यापना सहित), नारायण चन्द्र गोस्वामी, संस्कृत पुस्तक भाण्डार, कोलकाता.
16. भारतीय दर्शनेर रूपरेखा, अमित भट्टाचार्य, संस्कृत बुक डिपो, कोलकाता

| Course Code | Course Title / Topic  | Credit | TH +T U | MARKS DISTRIBUTION       |            |   |        |
|-------------|---|--------|---------|--------------------------|------------|---|--------|
|             |   |        |         | INTERNAL ASSESSMENT (IA) | ATTENDANCE | Comprehensive Continuous Assessment (CCA) | Theory |
| CC 14       | <b>Sanskrit Composition &amp; Communication</b>   |        |         |                          |            |   |        |
|             | <b>Section- A</b><br><b>Vibhaktyartha, Voice &amp; Kṛt</b><br><b>Allotted Marks-25</b><br><b>LH-35</b>  |        |         | 10                       | 10         | Project/<br>Tutorial                      | 65     |
|             | <b>Unit I</b><br>(i) Vibhaktyartha Prakaraṇa of Laghusiddhāntakaumudī<br>(ii) Voice (katṛ, karma and bhāva)<br><br><b>Unit II</b><br>Selections from Kṛt Prakaraṇa- | 06     | 5+1     |                          |            | 15  |        |

from Laghusiddhantakaumudī  
Major Sūtras for the formation  
of kṛdanta words (tavyat,  
tavya, anīyar, yat, ṇyat, ṇvul,  
Ṭṛc, Aṇ, kta, ktavatu, śatṛi,  
śāṇac,  
tumun, ktvā, lyap, lyuṭ, ghañ, ktin

**Section -B**  
**Allotted Marks-30**  
**LH-35**  
**Translation and**  
**Communication**

(i). Translation from  
Bengali/English to Sanskrit on  
the basis of cases(10marks),  
ii. Compounds and kṛt  
suffixes.(10marks)  
(iii). Translation from Sanskrit  
to Bengali and  
English(10marks)

**Unit II**  
**Allotted Marks-10**  
Communicative Sanskrit:  
Spoken Sanskrit.

**Section-C**  
**Essay**  
**Allotted Marks-35**  
**LH-30**

**Unit-I**  
Essay (traditional subjects)  
e.g.Veda, Upaniṣad, Sanskrit  
Language, Saṃskṛiti,  
Rāmāyaṇa, Mahābhārata,  
Purāṇa, Gītā, principal Sanskrit  
poets.

**Unit II**  
Essay based on issues and  
topic related to modern  
subjects like entertainment,  
sports, national and  
international affairs and social  
problems.